

Work procedures

Driver's and passenger's airbag units, visually checking

Driver's side airbag:

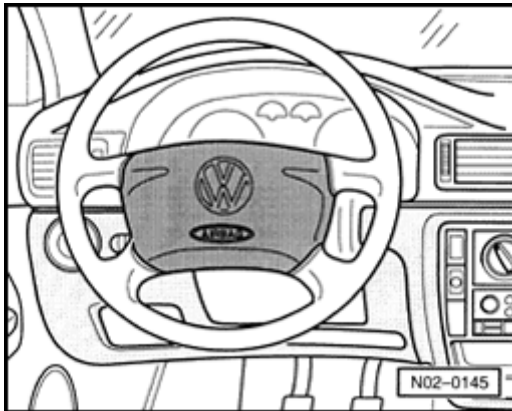

A

- Visually check airbag cover on steering wheel for signs of exterior damage.

WARNING!

- ◆ **The covers of the airbag units on the steering wheel, instrument panel, and side airbags must not be covered or have any objects affixed to them. Inform the customer once more about the importance of this point.**
- ◆ **Do not apply any chemical treatment to airbag covers. Clean with dry or water-moistened cloth only.**

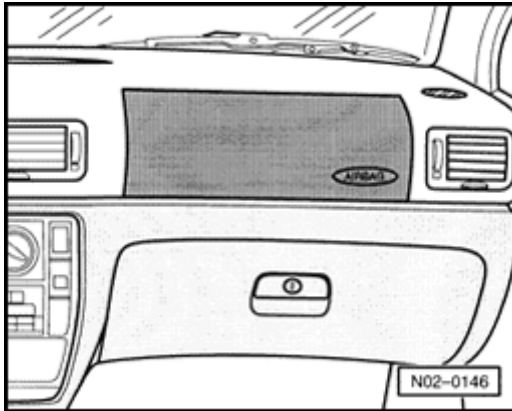

Front passenger's airbag:

A

- Visually check airbag cover on instrument panel for signs of exterior damage.

WARNING!

- ◆ *The covers of the airbag units on the steering wheel, instrument panel, and side airbags must not be covered or have any objects affixed to them. Inform the customer once more about the importance of this point.*
- ◆ *Do not apply any chemical treatment to airbag covers. Clean with dry or water-moistened cloth only.*

On Board Diagnostic (OBD), checking all systems

Check OBD Diagnostic Trouble Codes (DTC) in two ways:

- ◆ With V.A.G 1551 Scan Tool ⇒ [Page 36](#)

or with

- ◆ Vehicle Diagnosis, Testing and Information System VAS 5051 ⇒ [Page 38](#) .

On Board Diagnostic (OBD) Diagnostic Trouble Codes (DTC), checking with V.A.G 1551 Scan Tool:

Special tools and equipment

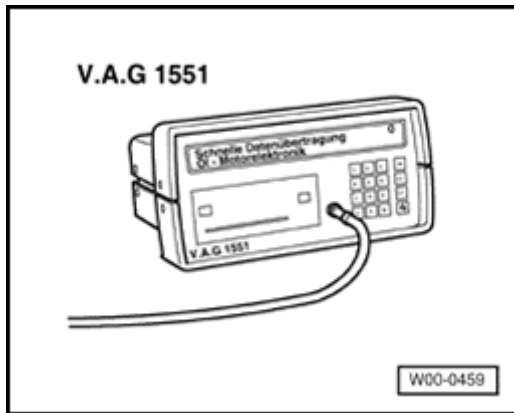

A

- ◆ V.A.G 1551 Scan Tool

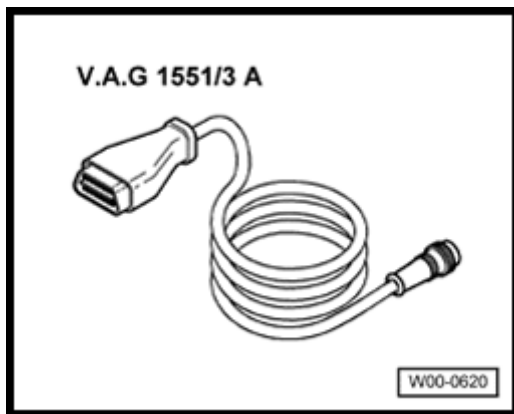

A

- ◆ V.A.G 1551/3 A adapter cable

Diagnostic Trouble Code (DTC), checking:

- Connect V.A.G 1551 Scan Tool ⇒ [Page 15](#) .
- Start engine and run at idle.
- Switch on printer with printer button (indicator light comes on).

V.A.G. On Board Diagnostic HELP
 1 - Rapid data transfer*
 2 - Blink code output*



Indicated on display

- Press button 1 for to select "Rapid data transfer".

Rapid data transfer HELP
 Input address word XX



Indicated on display

- Press buttons 0 and 0 to select address word "Automatic test sequence".

Rapid data transfer Q
 00 - Automatic test sequence



Indicated on display

- Confirm entry with Q-button. The V.A.G 1551 Scan Tool now sends all known address words.

If the control module answers with its identification code, the display shows the number of DTCs and or, if no DTC was found, the display will show "No DTC found".

Possible DTCs that are stored for a system will be shown one after the other and

printed. After that the V.A.G 1551 sends the next address word.

V.A.G. On Board Diagnostic HELP

1 - Rapid data transfer*

2 - Blink code output*

⚠ The automatic test sequence is ended when the following is displayed:

* appears alternately

- Switch ignition off.

If DTCs are found, a repair is necessary. Attach the DTC print-out to the repair order.

Note:

The scan tool V.A.G 1551 may have to stay connected for the emission control service.

Vehicle Diagnosis, Testing and Information System VAS 5051, checking DTC memory for all systems:

Special tools and equipment

- ⚠
- ◆ VAS 5051 Vehicle Diagnosis, Testing and Information System
 - ◆ VAS 5051/3 adapter cable

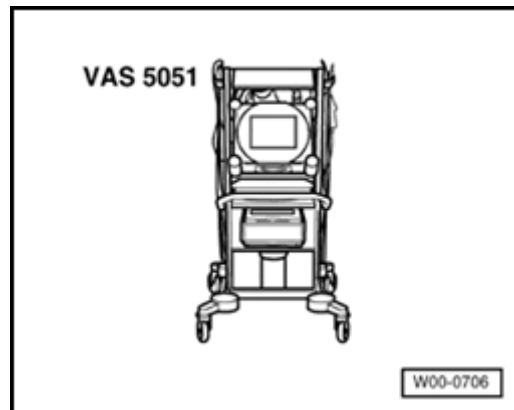

- Connect Vehicle Diagnosis, Testing and Information System VAS 5051 ⇒ [Page 16](#) .

- Switch ignition on.

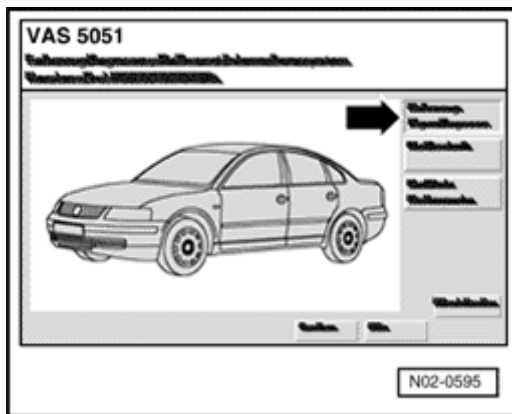

Indicated on display

Select function:

- On the display press button for "On Board Diagnostic" -arrow-.

Note:

If the display does not show the function:

⇒ *Operating Manual for Vehicle Diagnosis, Testing and Information System VAS 5051.*

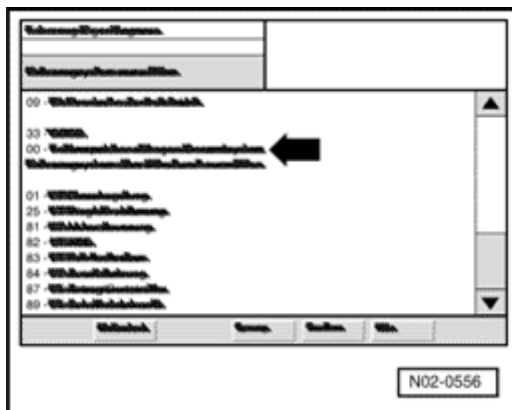

Indicated on display

Select vehicle system:

- On display press on "00 - Check Diagnostic Trouble Code (DTC)" -arrow-.

VAS 5051 will send all known address words one after the other.

If one of the control modules answers with its identification code, the display will show the number of DTCs or "0 DTCs recognized" will appear.

Possible DTCs of a system are shown one after the other. The VAS 5051 will then show the next address word.

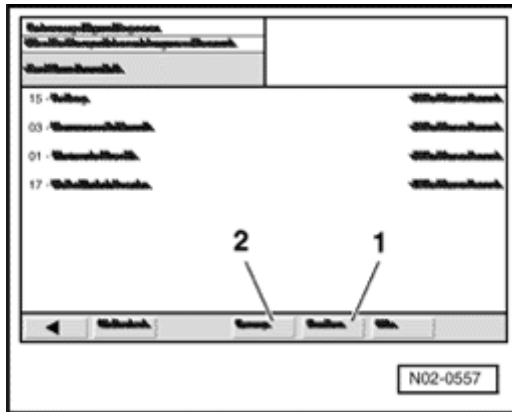

- A The automatic test sequence is ended when this is displayed
 - On display press button "Print" -1- and on print menu press "Screen Print".

The VAS 5051 will print out all DTCs or "0 DTC recognized". If a DTC was recognized, a repair is necessary. Attach the print-out to the repair order.

- Press "Go to" button -2-.

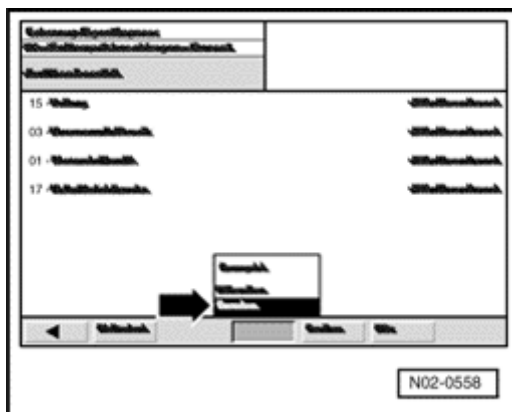

- A Indicated on display
 - Press "Exit" button -arrow-.
 - In exit menu press "Exit" button.
 - Switch ignition off and disconnect Data Link Connector (DLC).

Door check and securing bolts, lubricating

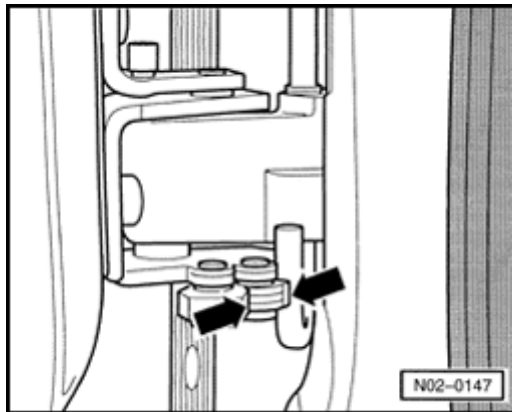

A

- Lubricate door check at points shown -arrows-.

Lubricant: grease G 000 400

Power roof, checking function, cleaning and lubricating guide rails

- Check function of power roof.

- Lubricate guide rails -arrows- with grease G 000 450 02.

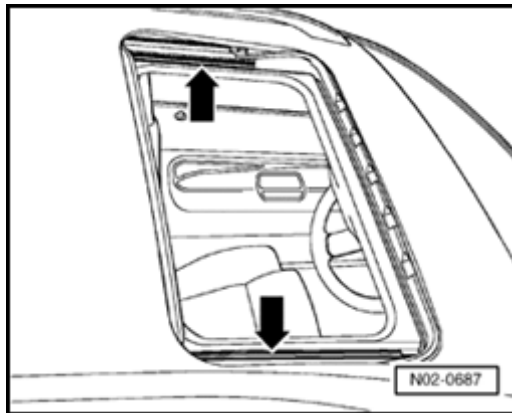

Power windows, activating

Note:

After disconnecting and connecting the battery, the up and down motion of the windows does not function. Before delivery of the vehicle, the power windows must be activated. After activation, the battery must not be disconnected.

WARNING!

After disconnecting and connecting the battery, the "pinch protection" is deactivated. Damage and personal injury can result!

To activate the power windows:

- Completely close all windows and doors.
- Lock vehicle from the outside either from the driver's or passenger's doors.
- Unlock vehicle.
- Again lock vehicle either from the driver's or passenger's door while holding key in the locked position for at least 1 second.

8-way memory seats, activating

Note:

After disconnecting and connecting the battery, the memory system for the power seat adjustment does not function. Before delivery of the vehicle, the power seats must be activated again. After activation, the battery must not be disconnected.

To activate the power seats:

- Open driver's door.

- Switch ignition on.

- Move seat forward to stop and up.

- Move seat backrest forward to stop.

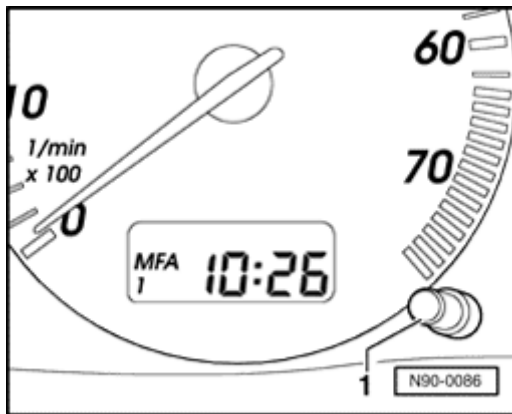

Clock, adjusting

Digital clock

Adjusting hours:

- Turn knob -1- counter-clockwise. The knob is located on the lower right side next to the tachometer.

Slightly turning the knob once advances the clock by one hour. Turning and holding the knob advances the hours continuously.

Adjusting minutes:

- Turn knob -1- clockwise.

Slightly turning the knob once advances the clock by one minute. Turning and holding the knob advances the minutes continuously.

With knob -1- , the clock can be precisely adjusted to the second:

- Turn knob clockwise until the clock is one minute short of the exact time.
- Turn knob clockwise the moment the second hand of another correctly adjusted watch reaches a full minute.

Analog clock

Adjust the clock as follows:

Note:

In the instrument cluster on the lower right next to the tachometer is the adjustment knob. Pull the knob to adjust the clock.

To adjust the clock one minute at a time:

- Briefly pull knob.

To move the pointer slowly and then gradually faster:

- Pull knob and hold.

Climatronic, adjusting temperature to 22 °C (72 °F)

Note:

By adjusting the temperature to 22 °C (72 °F), a comfortable climate is created for the vehicle's interior.

- Switch ignition on.
- Check whether 22 °C (72 °F) was adjusted ⇒ - 3- in the display.

If necessary, adjust the temperature as follows:

- Press knob -1- for automatic operation. In the display AUTO -2- will appear.
- By pressing knob -4- for "cooler" or button -5- for "warmer" adjust the temperature to 22 °C (72 °F).

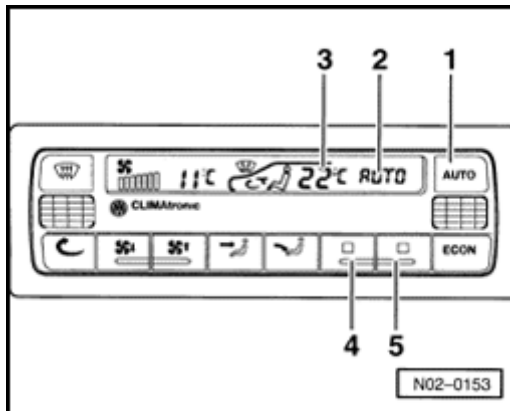

Radio anti-theft security code, inputting

"Premium III" ➤ 10.97 anti-theft security code, inputting

The security code is "fixed", meaning the radio is programmed by the radio manufacturer to accept only one code. This code must be input during the new vehicle delivery inspection, into newly installed or existing units that have been removed and reinstalled.

Prerequisites:

- ◆ Obtain security code, either from code card or from customer.
- ◆ Fuse 37 OK (S 237 in wiring diagram)

Inputting code / cancelling electronic lock-up

- Switch on radio
 - "SAFE" appears in radio display
- Press "Seek" and "Scan" buttons simultaneously until radio display indicates "1000".

Note:

Release the "Seek" and "Scan" buttons immediately after "1000" appears in display. Do Not continue to hold buttons down or press them again. This may cause the radio to consider 1000 to be the input code number.

- Input the security code found on the radio card using the station preset buttons on the radio. Button "1" corresponds to the first number in the security code, "2" the second and so on. Press the applicable button repeatedly until the desired number appears in the display (eg.: press button "2" three times if the second number in the code is 3).

Note:

For technical reasons, the first number in the security code can only be a "1" or left blank. The following three digits may be any number from 1 to 9.

- When the entire code has been input and appears on the display, press "Seek" and "Scan" buttons simultaneously.

The code is input properly when the display indicates "SAFE" and then a radio frequency (ready for use). When the radio is switched off and the ignition key removed, a flashing LED on the radio faceplate indicates the radio is security protected.

Incorrect code number

If an incorrect code is entered, "SAFE" will appear in the display (first blinking and then continuous) and the radio will not function. The entire coding procedure can only be repeated one more time immediately (the number of attempts is displayed).

If during the second attempt an incorrect code is entered, the radio will lock-up for approximately one hour. Leave radio switched on for 1 hour and attempt coding again when the number of attempts on display goes out (ensure proper code is available).

Cycle: 2 attempts - 1 hour lock-up still applies.

"Premium IV" 10.97 ➤ 08.99 anti-theft security code, inputting

The security code is "fixed", meaning the radio is programmed by the radio manufacturer to accept only one code. This code must be input during the new vehicle delivery inspection, into newly installed or existing units that have been removed and reinstalled.

Prerequisites:

- ◆ Obtain security code, either from code card or from customer.
- ◆ Fuse 37 OK (S 237 in wiring diagram)

Inputting code / cancelling electronic lock-up

- Switch on radio
 - "SAFE" appears in radio display, followed by "1000" approximately 3 seconds later.
- Input the security code found on the radio card using the station preset buttons on the radio. Button "1" corresponds to the first number in the

security code, "2" the second and so on. Press the applicable button repeatedly until the desired number appears in the display (eg.: press button "1" three times if the first number in the code is 3).

- When the entire code has been input and appears on the display, press the right side of the "Seek" button (">") for longer than 2 seconds until an audible signal is heard.

The code is input properly when the display indicates a radio frequency (ready for use). When the radio is switched off and the ignition key removed, a flashing LED on the radio faceplate indicates the radio is security protected.

Incorrect code number

If an incorrect code is entered, "SAFE" will appear in the display (first blinking and then continuous) and the radio will not function. The entire coding procedure can only be repeated one more time immediately (the number of attempts is displayed).

If during the second attempt an incorrect code is entered, the radio will lock-up for approximately one hour. Leave key in ignition, radio switched on for 1 hour and attempt coding again when the number of attempts on display goes out (ensure proper code is available).

Cycle: 2 attempts - 1 hour lock-up still applies.

"Premium V" (incl. "Monsoon") 08.99 ➤ anti-theft security code, inputting

The security code is "fixed", meaning the radio is programmed by the radio manufacturer to accept only one code. This code must be input during the new vehicle delivery inspection, into newly installed or existing units that have been removed and reinstalled.

Prerequisites:

- ◆ Obtain security code, either from code card or from customer.
- ◆ Fuse 37 OK (S 237 in wiring diagram)

Inputting code / cancelling electronic lock-up

- Switch on radio
 - "SAFE" appears in radio display, followed by "1000" approximately 3 seconds later.
- Input the security code found on the radio card using the station preset buttons on the radio. Button "1" corresponds to the first number in the

security code, "2" the second and so on. Press the applicable button repeatedly until the desired number appears in the display (eg.: press button "1" three times if the first number in the code is 3).

- When the entire code has been input and appears on the display, press the right side of the "Seek" button (">") for longer than 2 seconds until an audible signal is heard.

The code is input properly when the display indicates "LSM" (ready for use). When the radio is switched off and the ignition key removed, a flashing LED on the radio faceplate indicates the radio is security protected.

Incorrect code number

If an incorrect code is entered, "SAFE" will appear in the display (first blinking and then continuous) and the radio will not function. The entire coding procedure can only be repeated one more time immediately (the number of attempts is displayed).

If during the second attempt an incorrect code is entered, the radio will lock-up for approximately one hour. Leave key in ignition, radio switched on for 1 hour and attempt coding again when the number of attempts on display goes out (ensure proper code is available).

Cycle: 2 attempts - 1 hour lock-up still applies.

Windshield wiper and washer system, checking function

Note:

When checking the function, if the wiper blades skip or cause noise, check the contact angle of the blades ⇒ [Page 62](#) .

Wiper/washer system, checking or topping-up antifreeze

Special tools and equipment



- ◆ T10007 Refractometer

Note:

Read the exact value for the following test at the light/dark line. To better recognize the light/dark line, apply a drop of water with the pipette (dropping glass) onto the glass. The light/dark line should now be clearly visible at the "WATERLINE".

- Check concentration of antifreeze with refractometer T10007 (see operating instructions).



Scale -1- of refractometer applies to factory-filled antifreeze G 052 164.

Scale -2- applies to commercially available anti-freeze as well as to a mixture of commercial anti-freeze and G 052 164.

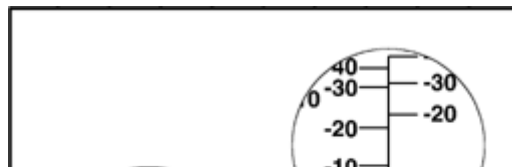
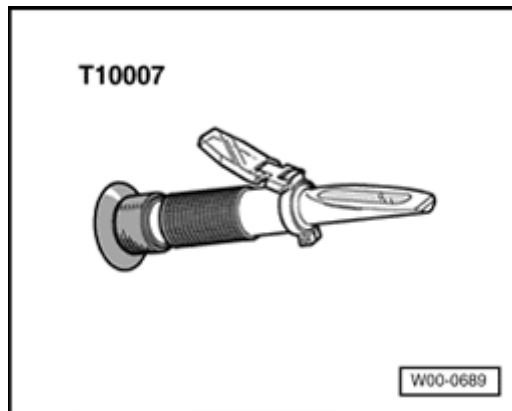

Mixing ratio:

Anti-freeze protection to	Anti-freeze	Water
	G 052 164	
-18 ° C (0 ° F)	1 Part	3 Parts
-23 ° C (-9 ° F)	1 Part	2 Parts
-38 ° C (-36 ° F)	1 Part	1 Part

The fluid reservoir must be filled to the top.

Use washer fluid VW G 052 164 or equivalent all year round.

- ◆ *All vehicles equipped with fan spray jets must be filled with VW G 052 164 or equivalent. These fluids have a low viscosity below freezing which helps to prevent the complicated sprayer system to be clogged with crystallized washer fluid. This would interfere with the fan-effect of the spray jets.*
- ◆ *Also during the warm season fill the reservoir with VW G 052 164 or equivalent. The strong cleaning effect cleans the wax-like and oily film from the window glass.*

- ◆ *The anti-freeze protection must be provided for about -15° C (9° F). For arctic climates the protection must be for about -35° C (-31° F).*

Windshield washer system, checking and adjusting spray jets

Note:

Do not clean spray jets against the spray flow by blowing air into the jets from the front.

Spray jets without pre-adjustment

The spray jets are pre-adjusted and have no height adjustment.

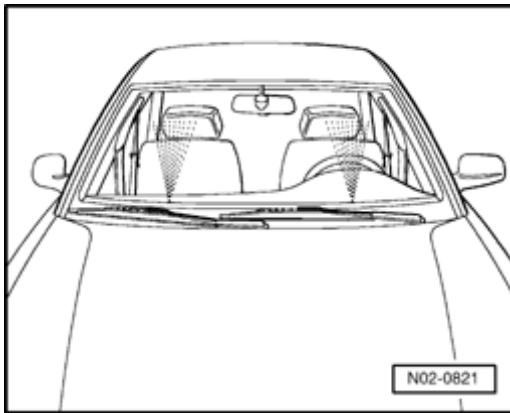

If both spray fields are not at the same level:

- Remove spray jet with lower spray field and replace it with one that has height adjustment (repair procedure).

The spray jets are pre-adjusted, however allow slight compensation of differences in height.

If the spray fields are not at the same level, correct the spray field up or down as follows:

Note:

Two different spray jet types were used in the production.

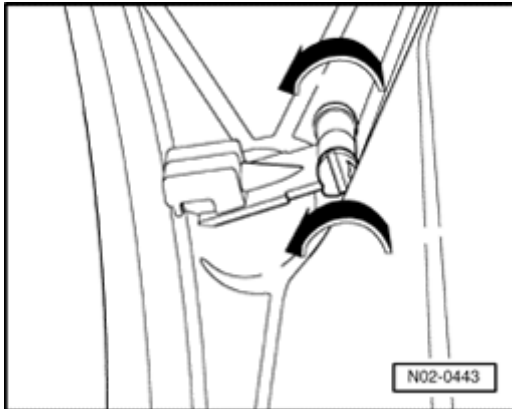

- A**
- Turn eccentric at spray jets in direction of arrow with a screwdriver to adjust spray upward.
 - Turn screwdriver against direction of the arrow to adjust spray downward.

or

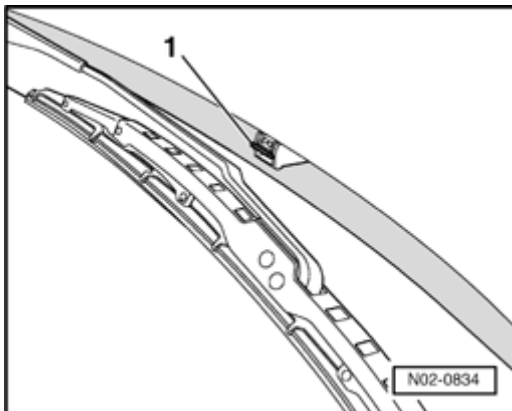

- A**
- Adjust spray at adjustment -1- by hand either up or down.

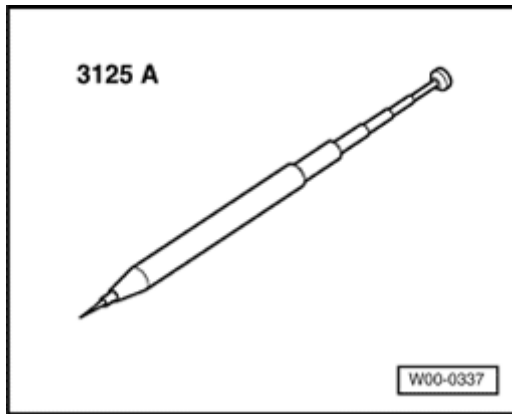

Rear window (Wagon)

Special tools and equipment

A

- ◆ 3125 A Adjustment tool for spray jet adjustment

Notes:

- ◆ *If the washer spray is uneven or if the jet cannot be adjusted to the desired area, replace the spray jet (repair procedure).*
- ◆ *Never use a needle or similar tool because the water channel of the spray jet can be damaged.*

- Check adjustment of spray jet:

Spray jet specification for rear window:

The spray must hit the middle of the wipe area.

- If necessary adjust spray jet with special tool 3125 A.

Headlight washer system, checking and adjusting spray jets

Special tools and equipment

- A ♦ 3019 A Adjustment device

Vehicles before production date 09.00

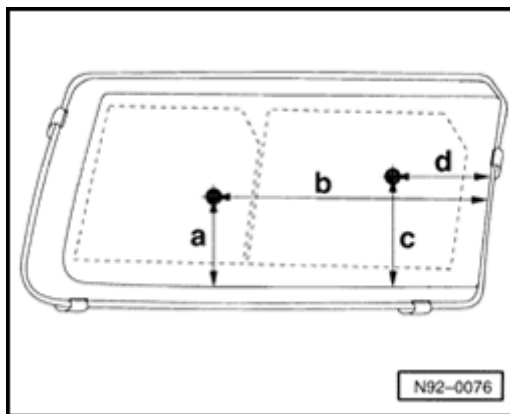
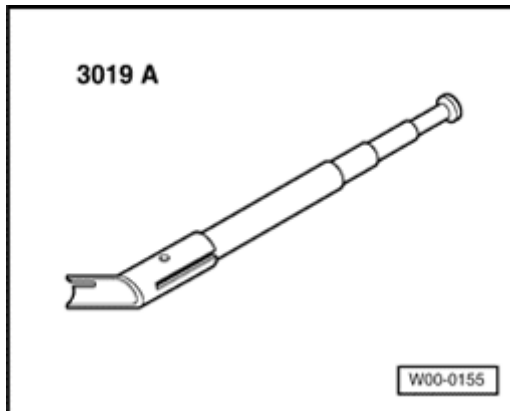

- A Spray jet adjustment for left headlight. Adjustment for right headlight is identical but reversed.

Spray jets, measurements

- a - 60 mm
- b - 205 mm
- c - 75 mm
- d - 80 mm

If necessary, adjust spray jets as follows:

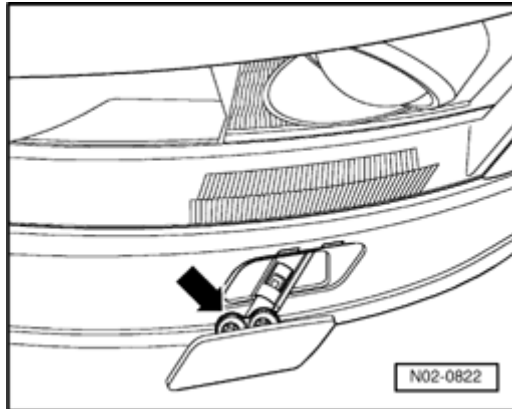

- A** - Pull spray jets out to stop and adjust spray to the applicable points using adjustment tool 3019 A.

Note:

If the spray is uneven or if it cannot be adjusted to specifications, the spray jet must be replaced (repair procedure).

Vehicles after production date 10.00

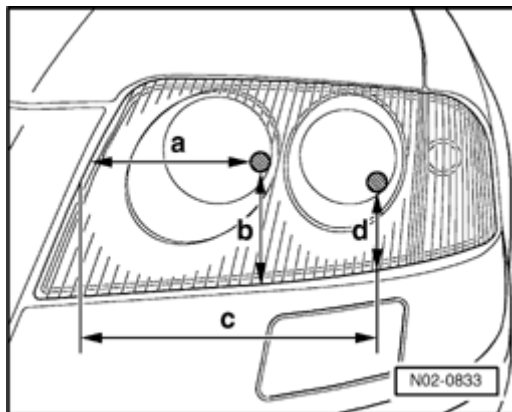

- A** Spray jet adjustment for left headlight. Adjustment for right headlight is identical but reversed

Spray jets, measurements

- a - 110 mm
- b - 75 mm
- c - 230 mm
- d - 50 mm

If necessary, adjust spray jets as follows:

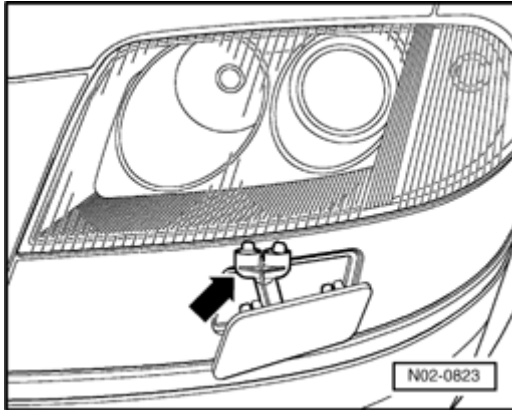
**A**

- Pull spray jets out to stop and adjust spray to applicable points using adjustment tool 3019 A.

Note:

If the spray is uneven or if it cannot be adjusted to specifications, the spray jet must be replaced (repair procedure).

Wiper blades, checking park position, adjusting contact angle

Wiper blade park position, checking and
adjusting

Special tools and equipment

A

- ◆ V.A.G 1331 Torque wrench (5 to 50 Nm)

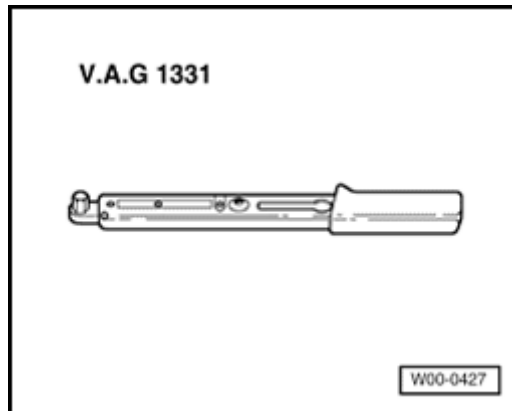

Windshield

Driver's side

Distance -A- between blade rubber insert and windshield lower edge must be 20 mm .

- If necessary adjust park position by resetting wiper arm.

Tightening torque for wiper blade: 20 Nm (15 ft lb)

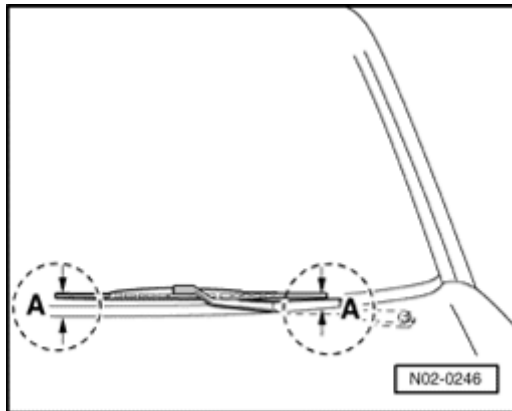

Passenger's side:

Distance -A- between blade rubber insert and windshield lower edge must be 20 mm

- If necessary adjust park position by resetting wiper arm.

Tightening torque for wiper blade: 20 Nm (15 ft lb)

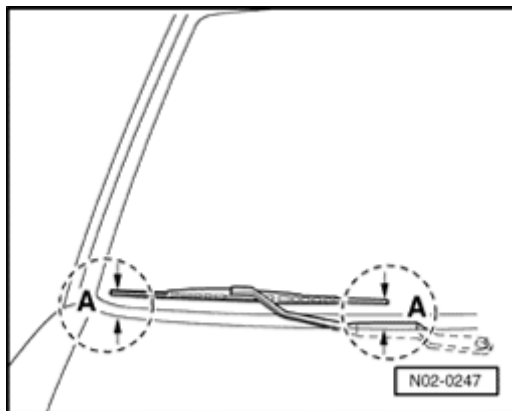

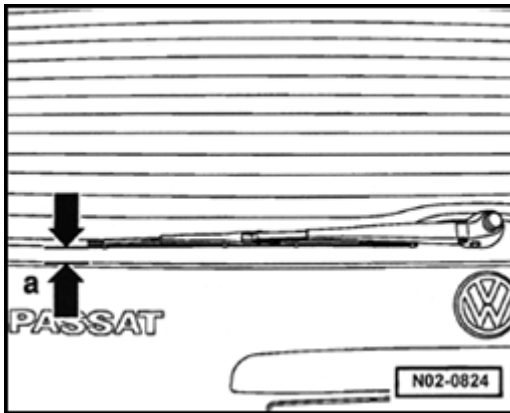

Rear window (wagon):

- A Distance -a- between blade rubber insert and window lower edge must be 25 mm .
 - f necessary adjust park position by resetting wiper arm.
- Tightening torque for wiper blade: 15 Nm (11 ft lb)

Wiper blade contact angle, checking and adjusting

Note:

Check contact angle only when wiper blades are noisy or skip.

Special tools and equipment

- A ♦ 3358 B Adjustment tool for wiper blades

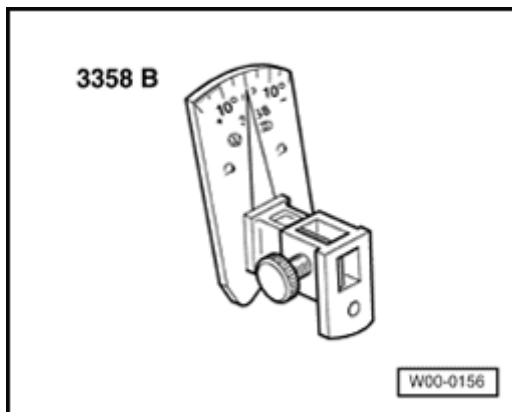

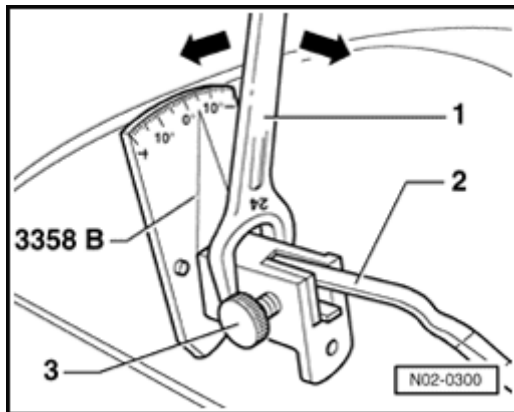

A

- Run wiper blades to park position.
- Remove wiper blade.
- Insert wiper arm -2- in adjustment tool 3358 B and lock with locking screw -3-.
- Check contact angle.

Contact angle (specified values) for		
	Left-hand drive vehicles	Right-hand drive vehicles
Driver's side	- 3°	+ 3°
Passenger's side	- 5°	+ 5°
Rear window	0°	0°
Tolerance	±2°	±2°

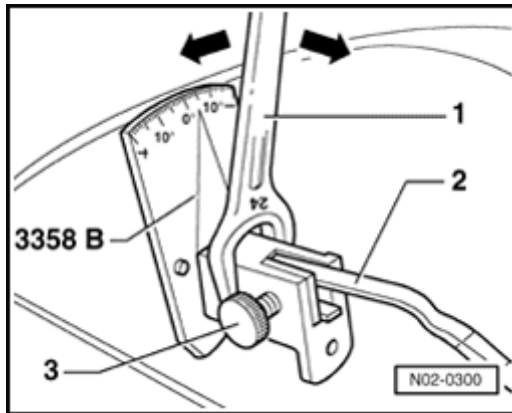

If necessary adjust contact angle to specified value as follows:

- Apply 24 mm open end wrench -1- on adjustment device and set wiper arm -2- to specified value -arrows-.
- Release wiper arm -2- from adjustment fixture and again tighten lock screw -3-.
- Compare adjusted value with specified value. If necessary repeat procedure until specified value is reached.
- Remove adjustment fixture and reinstall wiper blade.
- Check wiper blade operation.

Wheel bolts, checking torque

Special tools and equipment

A

- ◆ V.A.G 1332 Torque wrench (40 - 200 Nm)

Wheel cover, removing

The removal hook is part of the vehicle's tool kit.

Wheel bolts

The adapter for loosening and tightening of anti-theft wheel bolts is part of the vehicle's tool kit.

Note:

Be sure to tighten wheel bolts diagonally and alternately to the following specified torque:

Tightening torque: 120 Nm (88 ft lb)

- After completion of work, return adapter and hook for wheel cover to vehicle tool kit.

Full wheel cover, installing

A

- Install full wheel cover with tire valve positioned in the cut-out -arrow-.

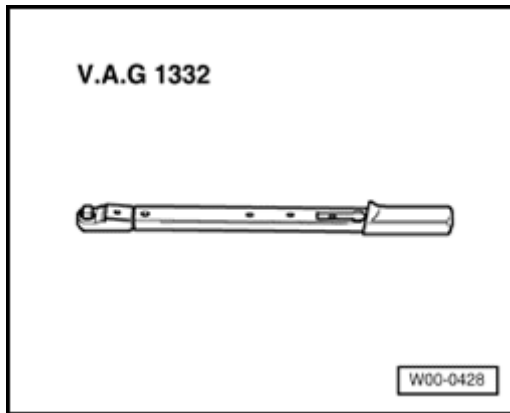

Tire condition, inflation pressure and tread depth, checking

Notes:

- ◆ *For safety reasons, all tires on the vehicle should be of the same make and tread design.*
- ◆ *For vehicles with all-wheel drive, the tires on the vehicle must be of the same make and tread design, otherwise the center differential may be damaged.*

Condition, checking

Pre-delivery inspection:

- Check tire tread surface and side walls for damage. If necessary remove imbedded foreign objects.

Note:

When detecting damage it must be determined whether the tire must be replaced.

Inspection Service:

- Check tire tread and side walls for damage, If necessary remove imbedded foreign objects.
- Check tire treads for cupping, feathering, one-sided tread wear, porous side walls, cracks, cuts, and rim damage.

Note:

Report any damage to customer and mark repair order accordingly.

Tread, checking

From the wear pattern of the tread it is possible to determine whether toe or camber needs to be checked.

- ◆ Feathered edges of the treads may indicate faulty toe adjustment.

- ◆ One-sided tread wear is mostly caused by faulty camber.

If such wear patterns are found, determine the causes by checking the wheel alignment (repair procedure).

Tread depth (including spare wheel), checking

- Check tread depth.

Minimum tread depth: 1.6 mm (1/16 in.)

Notes:

- ◆ *This specification may be different for some states or provinces. Always follow local or federal regulations.*

- ◆ *The minimum tread depth has been reached when the depth of 1,6 mm (1/16 in.) can be measured at several points of the wheel circumference or when the tread has worn down to the wear indicators located at several points on the circumference of the tire.*
- ◆ *If the tread wear is close to the wear limits, inform customer and note findings on the repair order.*

Tire pressure (including spare tire), checking and correcting

Special tools and equipment

- ◆ Tire pressure gauge

Notes:

- ◆ *Tire specifications as well as inflation pressure specifications are listed on the tire label located inside the fuel filler flap.*
- ◆ *The inflation pressure specifications refer to the air pressure of cold tires. Do not reduce tire pressure when the tires are warm.*

Transportation protection devices, removing from front axle springs (if installed)

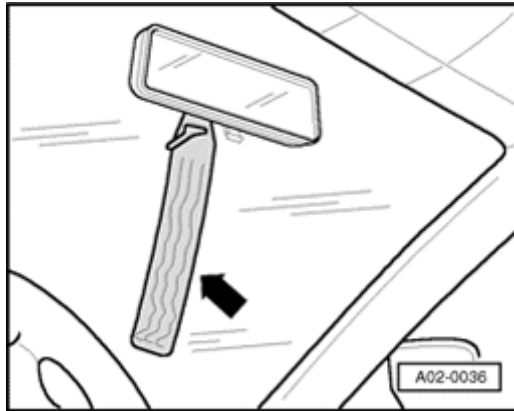

- A** For some models the front suspension struts have transportation protection devices installed. Such vehicles are provided with a tag attached to the rear view mirror - arrow-

Note:

The transportation devices are designed to prevent damage to the vehicle when driven onto railroad cars or road transport vehicles.

WARNING!

The transportation protection devices must be removed before delivery of the vehicle. The tag attached to the inside rear view mirror is a reminder of this important procedure.

Note:

It is not necessary to remove the wheels.

- Release tension of strut springs by lifting vehicle with lift.
- Remove transportation protection devices from struts.

Engine oil level, checking

After stopping the engine, wait for at least 3 minutes for the oil to flow back into the oil pan.

- Pull out oil dipstick and wipe with clean rag. Replace dipstick and push down to stop.
- Pull out dipstick again and read oil level:

A

If the dipstick appears as illustrated:

Area a- Oil must be topped up. It is sufficient when oil level is within area -b- after topping up.

Area b - Oil does not have to be topped up.

Area c - Oil must not be topped up.

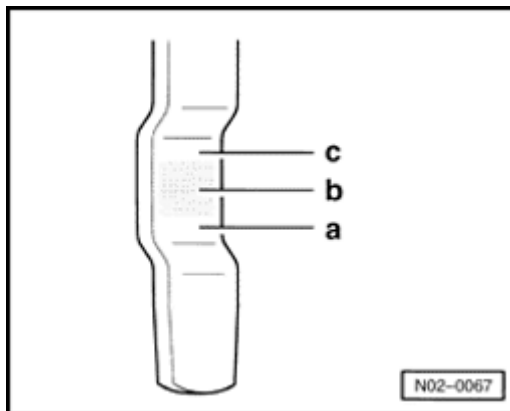

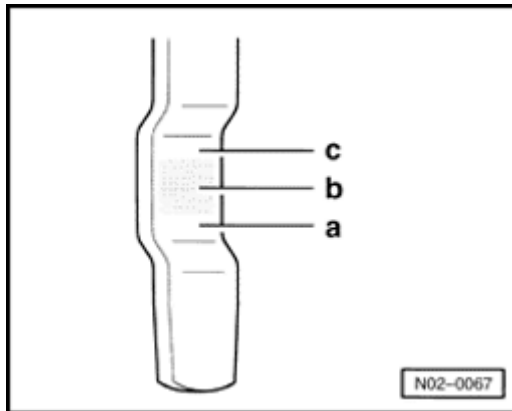
**Note:**

- ⚠ If oil level is above area -c- , the catalytic converter can be damaged.

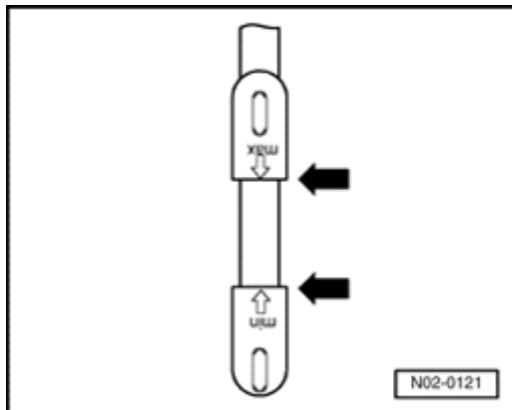

- ⚠ If the dipstick appears as illustrated:

The oil level must be between min.- and max.-markings. Be sure that the oil level is not above the max.-mark.

Notes:

- ◆ If the oil level is above the max. mark, the catalytic converter can be damaged.
- ◆ If the oil level is below the min.-mark, fill up with oil according to specifications ⇒ [Page 77](#) .

Engine oil, draining or siphoning; oil filter, removing and installing

Special tools and equipment

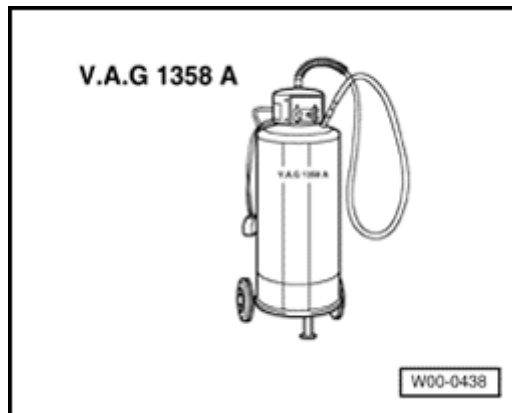

A

- ◆ V.A.G 1358 A Used oil siphoning equipment

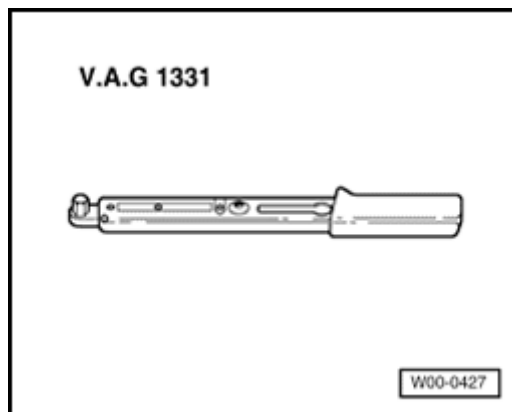

A

- ◆ V.A.G 1331 Torque wrench 5 to 50 Nm (44 in. lb to 37 ft lb)

Notes:

- ◆ *If the oil is drained and not siphoned, replace the gasket on the oil drain plug to prevent leaks (See Parts Catalog for correct application. In some cases, seal and drain plug are combined; do not interchange with separate seal and drain plug).*

- ◆ *Don't pollute. Dispose of old oil properly.*

Turbo engines: After replacing the oil and filter, do the following after the first engine start:

- While oil pressure warning light in instrument cluster is on, run engine at idle speed only. Do not accelerate. Acceleration bursts can either damage turbocharger or cause it to fail completely.

Only when the oil pressure warning light has gone out, full oil pressure has been reached and accelerating the engine is allowed.

Oil Capacities up to MY 2000

From my 2001 ⇒ Fluid Capacity Chart

Oil quantity with oil filter change:

Engine code	AUG, ATW	AHA
	AWM, AEB	ATQ
Oil capacity	3.9 Liters	5.0 Liters
With filter	(4.3 qt)	(5.7 qt)

- Remove sealing ring from oil drain plug, if necessary cut with side cutter.
- Drain engine oil.
- Install new seal on oil drain plug and tighten plug by hand.

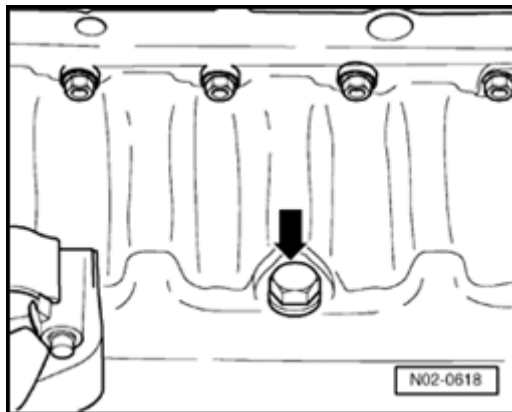

A **Torque specifications for oil drain plug -arrow-:**

Note:

Be mindful that the following torque specifications are not exceeded. A torque figure that is too high may lead to leaks or even damage the oil pan.

- ◆ 4-cyl. engines: 30 Nm (22 ft lb)
- ◆ 6-cyl. engine: 30 Nm (22 ft lb)

Replace if leaking. See Parts Catalog for correct application. In some cases, seal and drain plug are combined; do not interchange with separate seal and drain plug.

Because of the positive properties, only use the following oils:

Oil specifications for gasoline engines:

- ◆ Multi-viscosity energy conserving oils such as VW 500 00, or VW 502 00
- ◆ Multi-viscosity oil VW 501 01
- ◆ Multi viscosity oils according to API-SJor API-SL, SAE 5W-40 or SAE 10W-40

Note:

- ◆ *For vehicles after m. y. 1999, engine oil VW 503 00 must not be used, otherwise the engine may be damaged.*

Engine oil properties

Multi-viscosity oils VW 501 01 and 505 00 have the following properties:

- ◆ For all-year use in temperate climates
- ◆ Excellent cleaning ability
- ◆ Safe lubrication during all engine temperatures and load conditions
- ◆ High service life

Multi-viscosity energy conserving oil VW 501 00 has the additional properties:

- ◆ For all-year use in almost all climates
- ◆ Little energy loss through friction
- ◆ Best possible starting ability, also at very low temperatures.

Multi-viscosity energy conserving oil VW 502 00:

This engine oil specifically formulated for gasoline engines fulfilling specifications for VW 501 01 as well as 500 00 provides for the following additional advantages:

This oil is especially suited for extreme driving conditions, such as difficult road conditions, trailer towing, driving predominately in mountainous regions and in hot climates.

Notes:

- ◆ *Single viscosity oils are not normally suitable for year-round driving because of their limited viscosity range. Therefore such oil must only be used in extreme climate zones.*

- ◆ *When using multi-viscosity oils with the specification SAE 5 W-30, avoid prolonged driving with high engine rpm and prolonged high loads. This restriction does not apply to energy conserving oils.*

- After filling the engine with the appropriate amount of oil, wait for at least 3 minutes before checking the oil level with the oil dipstick.

- Remove oil dipstick, wipe with clean rag and insert dipstick again to stop.

Note:

Don't pollute! Return used oil to collection centers.

- Pull out oil dipstick again and read oil level.

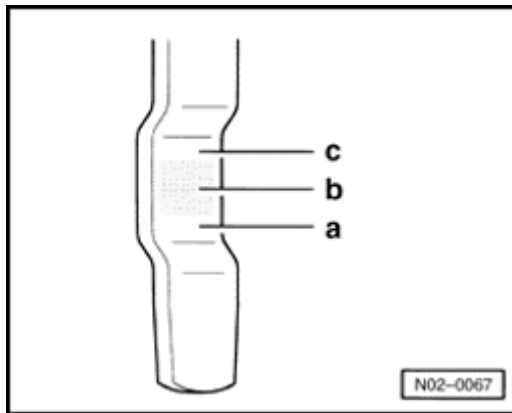

A For illustrated dipstick:

Area a- Oil must be topped up. It is sufficient when oil level is within area -b- after topping up.

Area b - Oil does not have to be topped up.

Area c - Oil must not be topped up.

Note:

If oil level is above area -c- , the catalytic converter may be damaged.

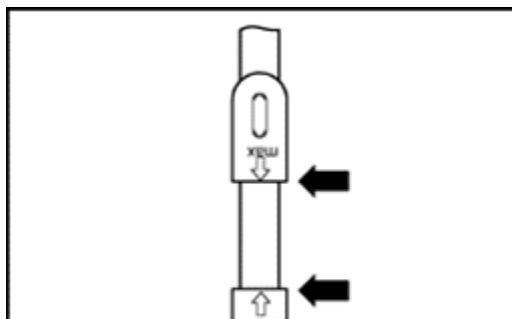

A If the dipstick appears as illustrated:

The oil level must be within the area between min. and max.-marks. The oil level must not go over the max.-mark.

Note:

If the oil level is above the max. mark, the catalytic converter may be damaged.

Oil filter, removing and installing

Special tools and equipment

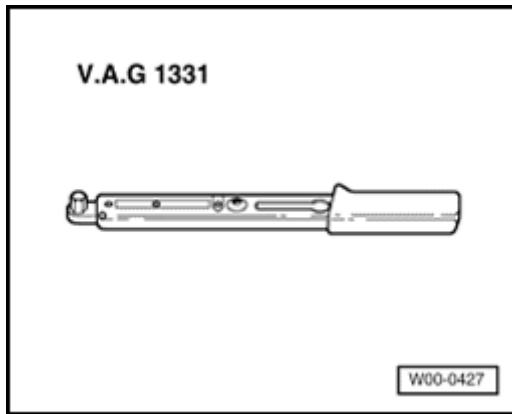

A

- ◆ V.A.G 1331 Torque wrench 5 to 50 Nm (44 in. lb to 37 ft lb)
- ◆ Oil filter wrench

or

- ◆ Oil filter strap wrench
- ◆ Shop rag

4-cyl and 6-cyl engines:

A

- Cover hole -1- of engine/transmission carrier with rag. This prevents old oil from entering carrier.

Note:

Don't pollute! Return used oil to collection centers.

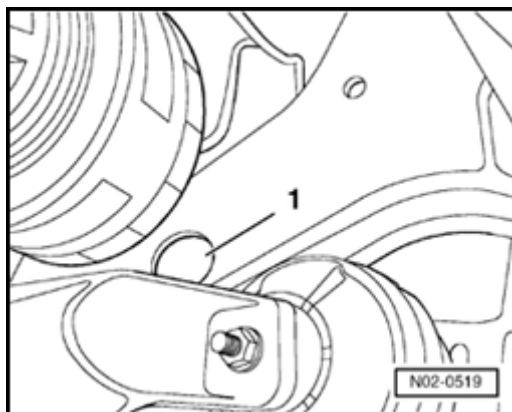

Engine and components in engine compartment (from above and below), visually checking for leaks and damage

- Check engine and components in engine compartment for leaks and damage.

- Check lines, hoses and connections for leaks, chafing, porosity and breaks of:
 - ◆ Fuel system

 - ◆ Cooling and heating systems

 - ◆ Brake system

Notes:

- ◆ *Report all faults for subsequent repairs.*

- ◆ *For fluids that are missing for reasons other than normal depletion, determine cause and repair (repair procedure).*

V-belt, removing and installing (4-cyl. engine)

Special tools and equipment

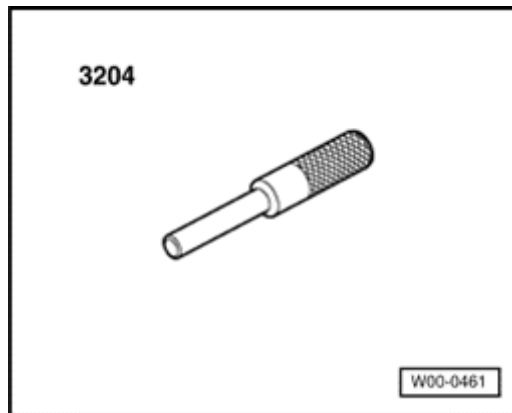

A

- ◆ 3204 drift

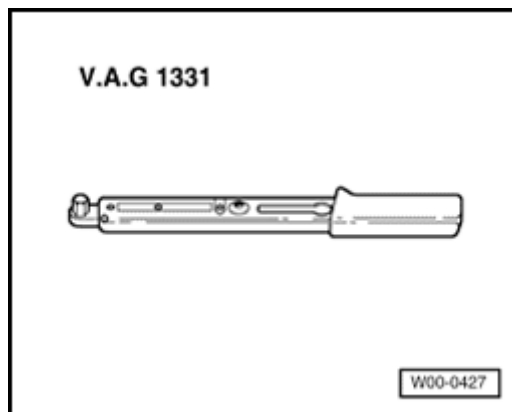

A

- ◆ V.A.G 1331 Torque wrench 5 to 50 Nm (44 in. lb to 37 ft lb)
- ◆ Drift 5 mm (0.19 in.) dia.

Removing

- Set lock carrier to service position:

⇒ [Repair Manual Body Exterior, Repair Group 50](#)

- Mark running direction of belt if it is to be used again.

Note:

Be sure to install the belt in the correct running direction. If installed against the running direction, the belt will be damaged.

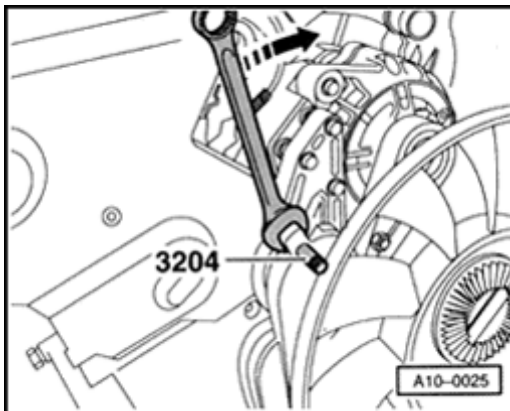

A

- To slacken belt, move wrench in direction of arrow.
- Lock tensioning device using drift 3204.

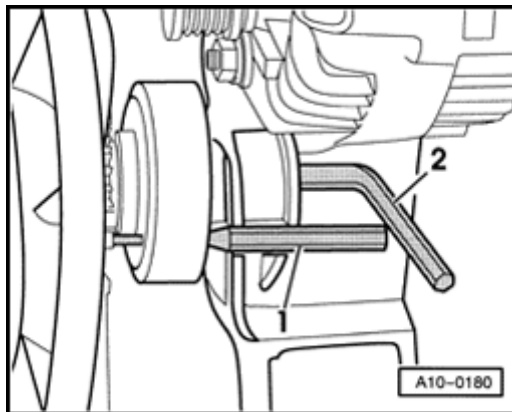

- Remove ribbed belt.
- Remove fan from viscous fan pulley.
- A
 - Lock belt pulley to viscous fan pulley using drift -1-.
 - Remove bolt for viscous fan pulley with 8 mm socket-head wrench -2- and remove viscous fan pulley together with belt pulley.
 - Mark installation position of two-part belt pulley in relation to cooling pump.

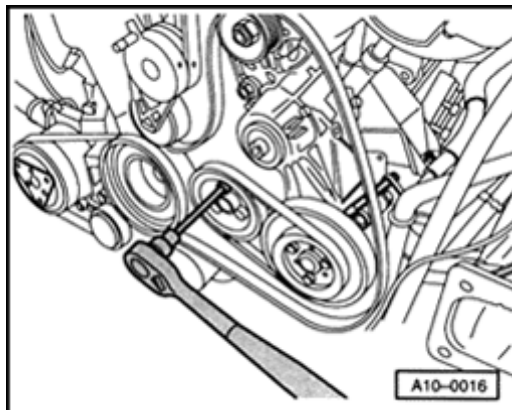

- A
 - Lock belt pulley of power steering pump with drift.
 - Remove two-part belt pulley of coolant pump and remove belt.

Installing

- Attach 2-part belt pulley to coolant pump and install new belt between coolant pump and power steering pump.
- Tighten belt pulley evenly until belt has moved to outside of its running surface. If necessary turn power steering pulley or coolant pump pulley.

- Lock power steering pump with drift.
- Tighten belt pulley with 25 Nm (18 ft lb) to coolant pump.

Note:

Adding shims to tighten belt tension is not necessary.

- Push on viscous fan and install ribbed belt on fan.
- Tighten belt pulley to viscous fan pulley with 30 Nm (22 ft lb).
- Tighten viscous fan pulley to 45 Nm (33 ft lb).
- Install ribbed belt.

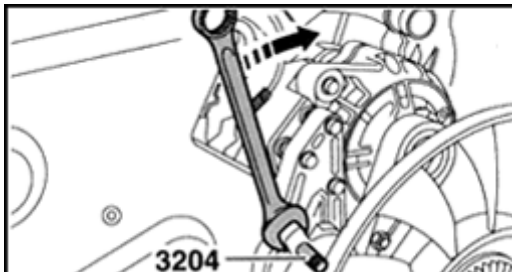

A

- Tension belt by removing pin 3204.

Note:

When installing belt be sure it fits properly in pulleys.

- Start engine and check belt performance.

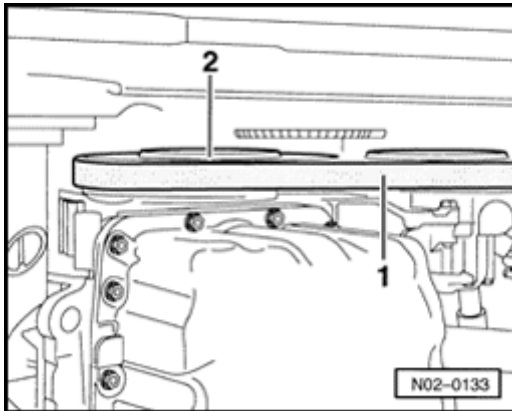

Ribbed belt, checking

A

- Turn engine at vibration damper/ belt pulley -2- with socket wrench .
- Check belt -1- with raised vehicle from below for:
 - ◆ Belt substrata breaks or cracks
 - ◆ Separation (cover layer, belt cords)
 - ◆ Breaks at lower layer
 - ◆ Fraying of cords
 - ◆ Wear at flanks (material wear, frayed flanks, hardening or glazing of flanks, surface cracks)
 - ◆ Oil or grease contamination

Note:

Replace the belt if any damage is found. Replacing the belt is a repair procedure.

Axle boots, checking

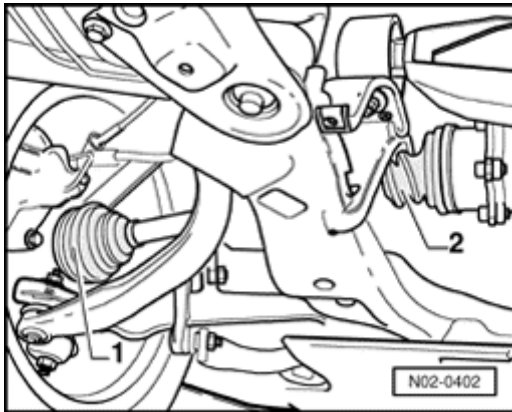

A

- Visually check outside axle boots -1- and outside axle boots -2- for leaks and damage.

Note:

For vehicles with all-wheel-drive also check boots at rear axle.

Manual transmission and final drive, checking oil level

Special tools and equipment

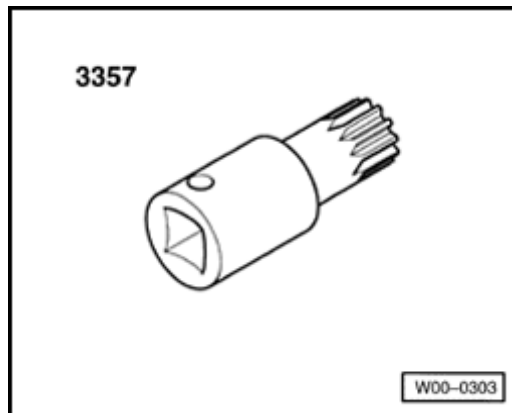

- A ♦ 3357 socket wrench (only for 012/01W transmission)

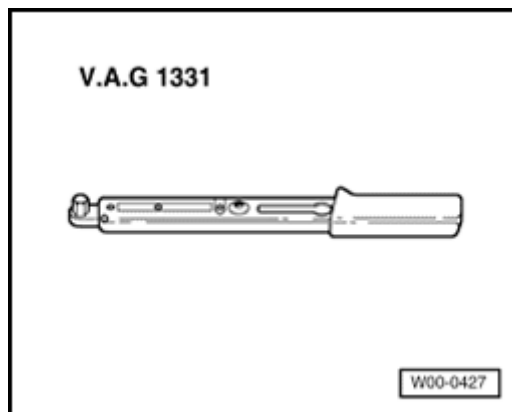

- A ♦ V.A.G 1331 Torque wrench 5 to 50 Nm (44 in. lb to 37 ft lb))

Transmission code is located on vehicle data sticker ⇒ [Page 19](#) .

5-Gear manual transmission 012/01W/01A

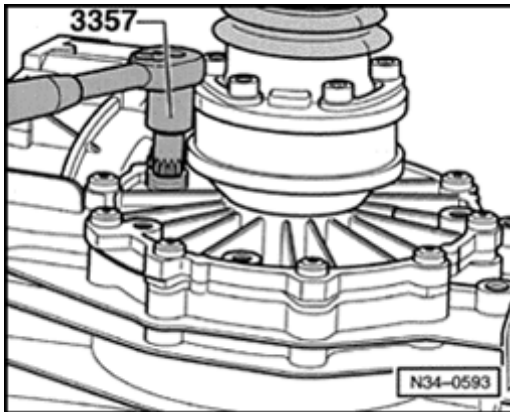

A

- Remove oil plug with socket wrench 3357.
- Check oil level: Oil level must be at lower edge of oil plug hole.
- If necessary top up with transmission oil G 052 911 A SAE 75W90 (synthetic oil) to lower edge of oil filler hole.
- Reinstall oil plug and tighten to 25 Nm (18 ft lb).

Automatic transmission final drive oil level, checking

Special tools and equipment

A

- ◆ V.A.G 1331 Torque wrench (5 to 50 Nm)

The transmission code is listed on the vehicle data sticker ⇒ [Page 19](#) .

Automatic transmission 01V

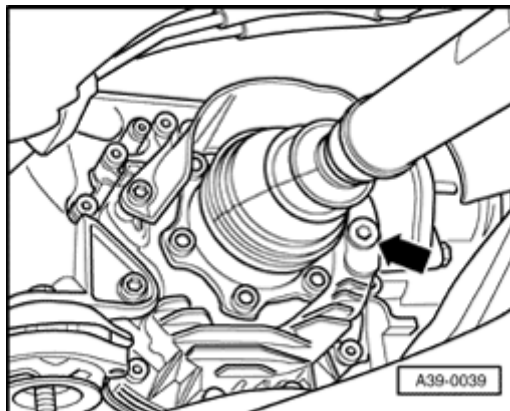
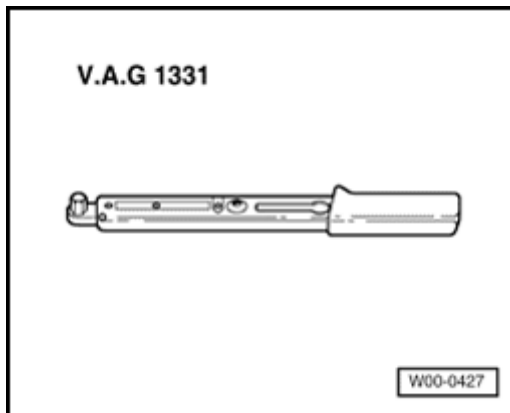

A

- Remove oil filler plug -arrow-.
- Replace seal of oil filler plug.
- Check oil level: Oil level must be at lower edge of oil filler hole.
- If necessary top up with SAE 75 W 90 (synthetic).
- Tighten oil filler plug to 30 Nm (22 ft lb).

Brake system, checking

Check components for leaks and damage:

- ◆ Main brake cylinder
 - ◆ Brake booster (for ABS check hydraulic unit)
 - ◆ Brake pressure regulator
 - ◆ Calipers
- Check that brake hoses are not twisted.
 - Turn steering to left stop and to right stop.
During this operation no brake hose must touch any vehicle components.
 - Check brake hoses for porosity and cracks.
 - Check brake hoses for chafing.
 - Check all brake connections for tight fit, leaks or corrosion.

WARNING!

Eliminate any faults (repair procedure).

Brake pads (front and rear), checking thickness

Special tools and equipment

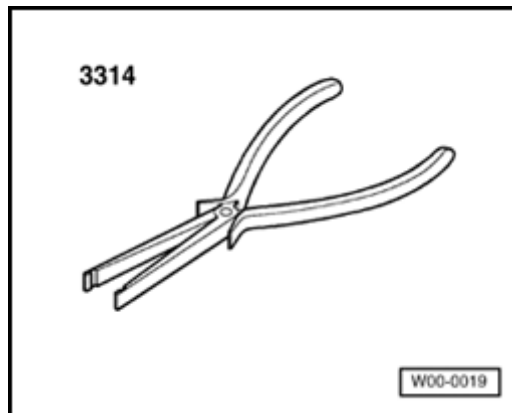

A

- ◆ 3314 Pliers

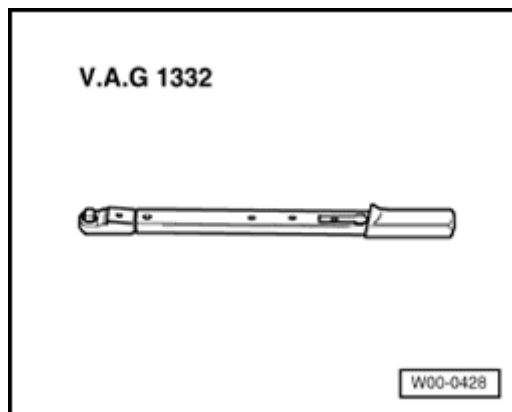

A

- ◆ V.A.G 1332 Torque wrench 40 to 200 Nm (30 to 148 ft lb)
- ◆ Flashlight and mirror

Remove full wheel cover

The removal hook is part of the vehicle's tool kit.

Wheel bolts

The adapter for loosening and tightening theft protection wheel bolts is part of the vehicle's tool kit

Brake pads front:

To better check thickness of brake pads, remove wheel on driver's side.

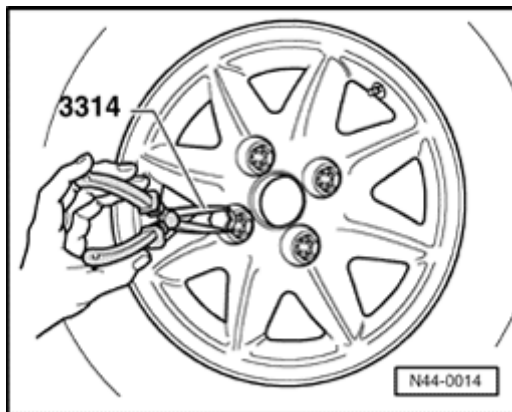

A

- If necessary, remove wheel lug covers with pliers 3314 or remove full wheel cover.
- Mark installation position of wheel in relation to brake rotor.
- Remove wheel lug bolts and remove wheel.
- Measure thickness of inner and outer brake pad.

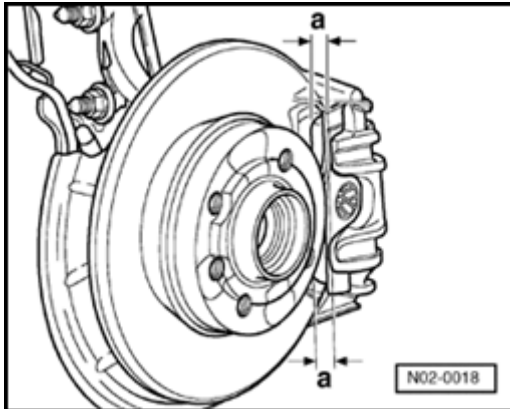

A

a - Pad thickness including backing plate

Wear limit 7 mm (0.27 in.)

With pad thickness (including backing plate) of 7 mm (0.27 in.), the brake pads have reached their wear limit and must be replaced (repair procedure). Be sure to notify customer and mark findings on repair order.

- Install wheel in previously marked position.
- Tighten wheel bolts diagonally and alternately to:
Tightening torque: 120 Nm (89 ft lb)
- After completing work store tools in vehicle tool kit.
- If necessary install wheel bolt caps.

Full wheel cover, installing

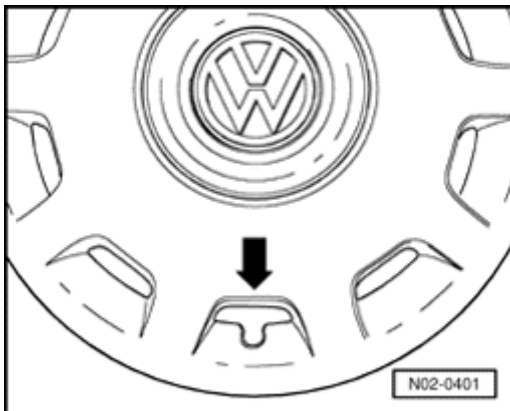

A

- Install wheel cover with opening -arrow- lining up with tire valve.

Brake pads, rear:

- If necessary remove full wheel cover.
- Using a flashlight and looking through opening, check brake pads.

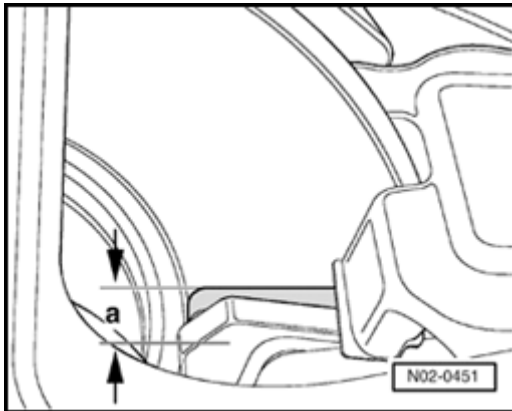

A

- Check thickness of outer pads visually.
- With flashlight light up inner brake pad and position mirror.
- Check thickness of inner pads visually.

a - Pad thickness including backing plate;

Wear limit 7 mm (0.27 in.)

With pad thickness (including backing plate) of 7 mm (0.27 in.), the brake pads have reached their wear limit and must be replaced (repair procedure). Be sure to notify customer and mark findings on repair order.

- If necessary install full wheel covers ⇒ [Page 95](#) .

Underbody sealant, checking

When checking the underbody sealant also check wheel wells and sill panels.

Note:

Any damage found must be corrected to prevent corrosion (repair procedure).

Tie rod ends, checking

- With vehicle raised (wheels off ground) check tie rods by moving tie rods and wheels. There must be no play.

- Check attachments

- Check upper control arm boots -1- and tie rod boots -2- for damage and proper seating.

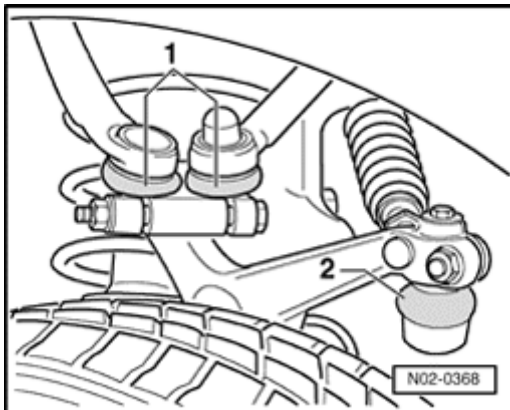

A

Control arm joints, checking

A

- Check boots -arrows- for damage and leaks.

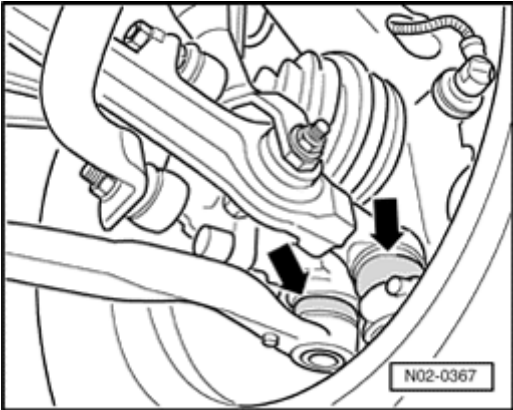

Engine coolant level and anti-freeze, checking

Note:

All engine coolant systems are filled with G 12 according to TL VW 774 D. Be sure to only use G 12 (color red) when topping up.

CAUTION!

- ◆ **Engine coolant -G12- must not be mixed with other coolant anti-freeze. Mixing with other coolants can cause serious engine damage.**
- ◆ **When the coolant has been mixed (color: brown), it must be changed (repair procedure).**

Engine coolant level, checking

- Check coolant level at coolant expansion tank when engine is cold.



A

- ◆ Pre-delivery inspection: engine coolant level must be at max. mark
- ◆ Inspection Service: Coolant level must be between min.- and max. -marks

- If coolant level is too low, top up according to mixing ratio.

Note:

If coolant loss is not caused by normal evaporation, check cause and repair (repair procedure).

**Mixture ratios:**

Frost protection to	G 12 antifreeze amount	Water
-25 ° C (-13 ° F)	approx.. 40%	approx. 60%
-35 ° C (-31 ° F)	approx. 50%	approx. 50%
-40 ° C (-40 ° F)	approx. 60%	approx. 40%

Notes:

- ◆ *G12 coolant additive according to TL VW 774 D prevents frost and corrosion damage, scaling and also raises the boiling point of the coolant. For this reason the system must be filled with G12 coolant additive all year.*
- ◆ *Especially in countries with tropical climates or when vehicle is driven under heavy load, the coolant improves the engine reliability by its increased boiling point.*
- ◆ *The coolant concentration must not be reduced by adding water, even during the warmer*

season. The anti-freeze ratio must be at least 40% .

Mixture ratio, checking

Special tools and equipment

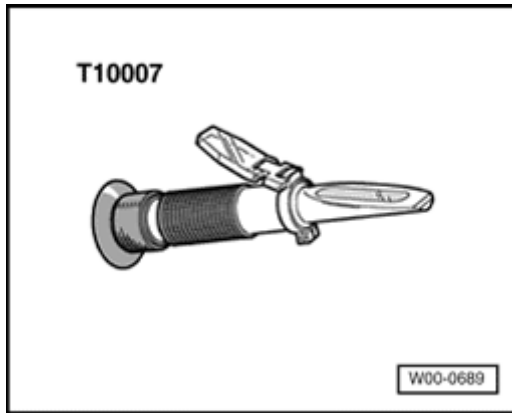

A

- ◆ T10007 Refractometer

Note:

Read the exact value for the following test at the "light/dark" line. To see the light/dark line, apply a little water using the drop glass on the glass. The light/dark line should now be clearly visible at the "WATERLINE".

- Check mixture ratio with refractometer T10007 (see user instructions)

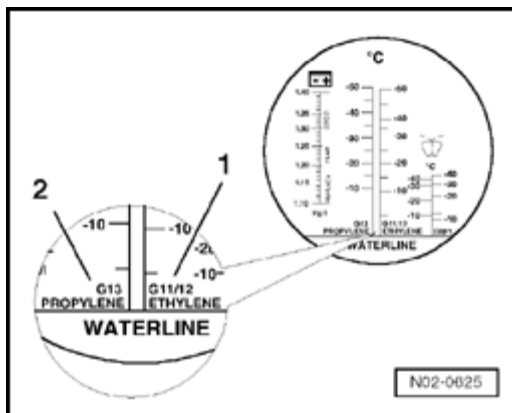

A

Scale -1- of refractor applies to coolant additive G 12 according to TL VW 774 D and -G 11- according to TL VW 774 C.

Scale -2- refers to coolant additive G 13.

Notes:

- ◆ Coolant additive G 13 is presently used only in vehicles of model "L 80".
- ◆ Anti-freeze protection must be for approx. -25°C (-13°F). In cold climates the protection must be for about -35°C (-31°F).
- ◆ If climate conditions make greater anti-freeze protection necessary, the amount of G 12 can be increased up to 60 % (anti-freeze protection to not more than. -40°C (-40°F)). Adding more anti-freeze reduces the protection again and also

reduces the cooling protection.



- If anti-freeze ratio is too low, drain listed amount and replace it with G 12.

Note:

Don't pollute! Dispose of used coolant according to local regulations.

Mixing ratios

Anti-freeze to °C		Difference amount in liters. (Drain this amount and replace with G 12)	
Actual	Specified	4-cyl engine	6-cyl engine
0	-25	3.5	5.0
	-35	4.0	6.0
-5	-25	3.0	4.5
	-35	3.5	5.5
-10	-25	2.0	3.5
	-35	3.0	4.5
-15	-25	1.5	2.5

	-35	2.0	3.5
Continued on next page			



Anti-freeze to ° C		Difference amount in liters. (Drain this amount and replace with G 12)	
Actual	Specified	4-cyl engine	6-cyl engine
-20	-25	1.0	1.5
	-35	1.5	2.5
-25	-35	1.0	1.5
-30	-35	0.5	1.0
-35	-40	0.5	0.5

- Check anti-freeze ratio once more after road test.

Spark plugs, removing and installing

Special tools and equipment

A

- ◆ 3122 B Spark plug wrench

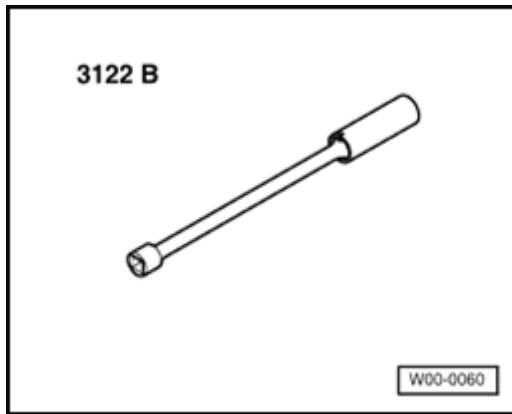

A

- ◆ T10029 Removal/installation tool

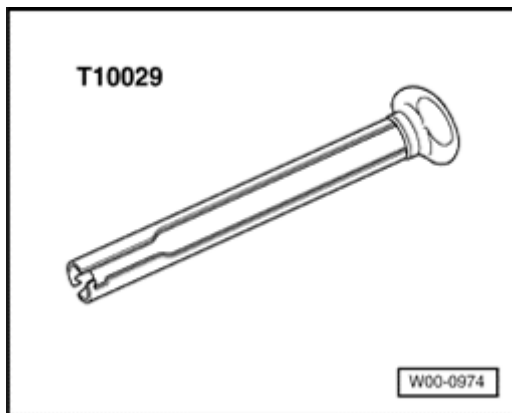

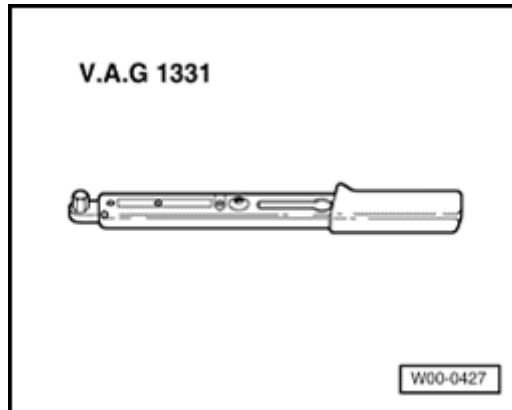

- ◆ V.A.G 1331 Torque wrench 5 to 50 Nm (44 in. lb to 37 ft lb)

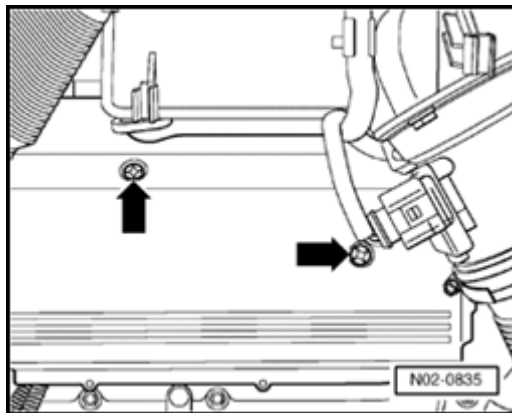

- ◆ - If covers for cylinder heads are installed, remove screws -arrows- and remove covers upward.

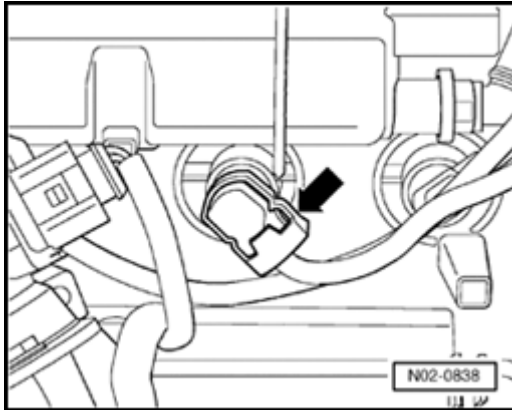

A

- If spark plug connector is equipped with tool for removal of spark plug connectors -arrow-, remove it.

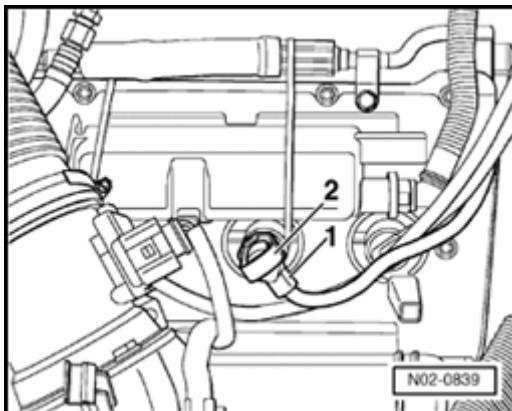

A

- Remove spark plug connector -1- with tool -2- . If there is no tool, remove connectors with removal/installation tool T10029.

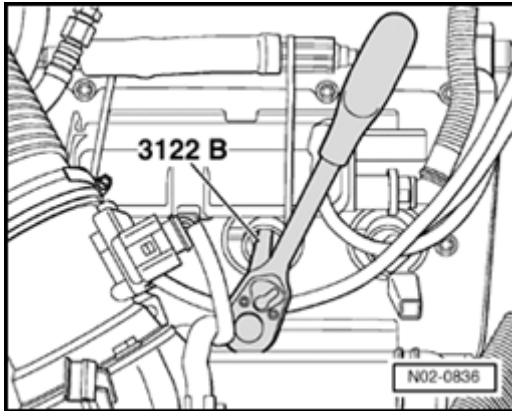
**A**

- Remove spark plugs with spark plug wrench 3122 B.

Note:

Observe local regulations regarding disposal of spark plugs.

- Install new spark plugs with wrench 3122 B.
- Install spark plug connectors.
- Check ignition cables and connectors for proper connections.
- Install engine covers.



Dust and pollen filter element, replacing

Vehicles before production date 09.00

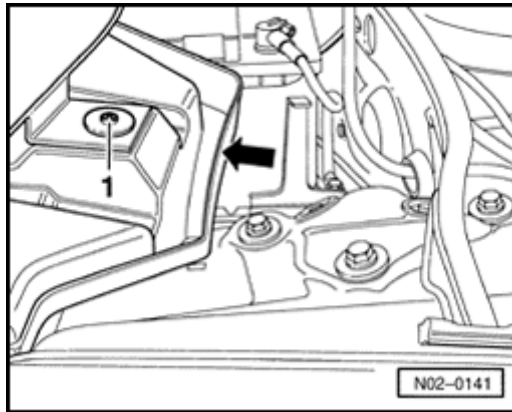

- A** Filter is located on right side in plenum chamber under cover -arrow-.

Removing

- Remove bolt -1- and remove cover.

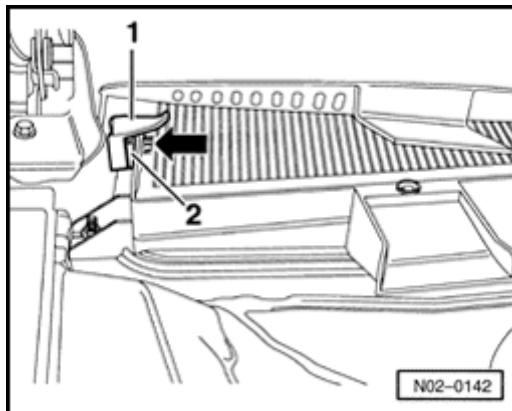

- A**
- Pull retainer -1- up.
 - Push up filter and pull forward to remove.

Note:

Observe local regulations for disposal of filter elements.

Installing

Note:

When installing be sure that marking "TOP-OBEN" on filter element points upward.

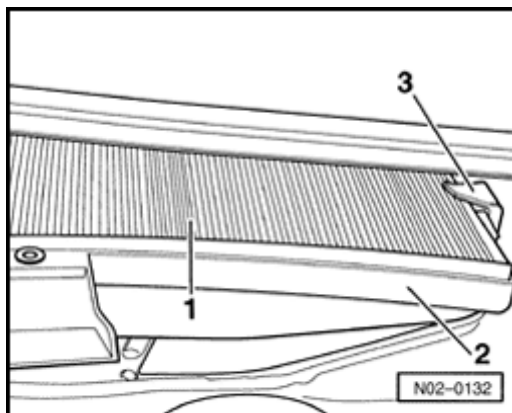

- A - Install new filter element -1- in bracket -2-.
- Push filter element under retainer -3- to stop.

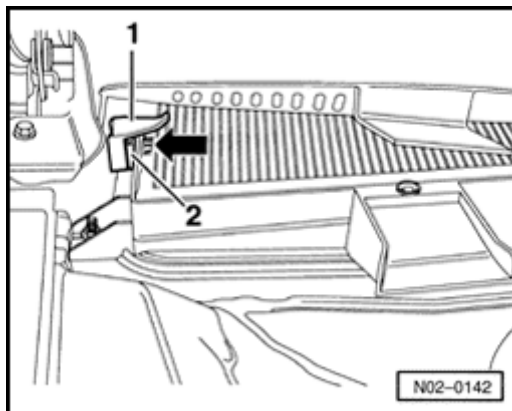

- A - Push retainer -1- into spring clip -2-.

Note:

Both retainers hold the filter insert in the frame bracket.

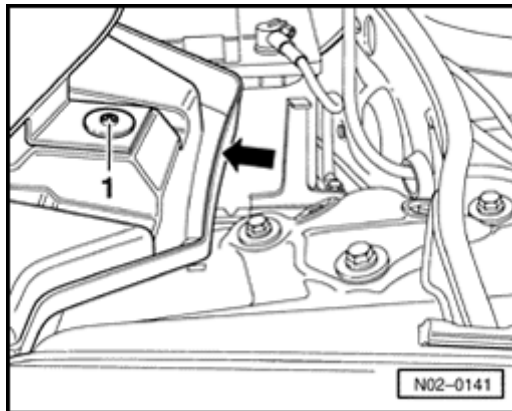

- A**
- Install cover -arrow- with bolt -1-.

Vehicles after production date 10.00

Filter is located on right side in plenum chamber under cover -arrow-.

Removing

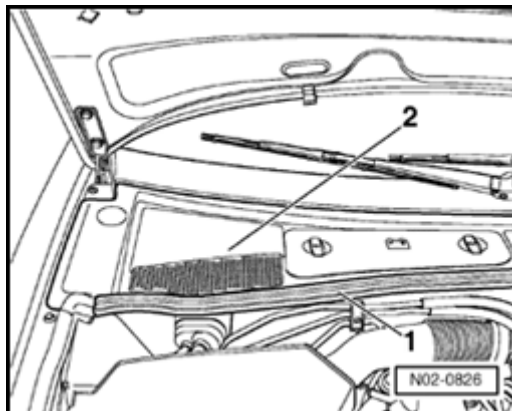

- A**
- Remove plenum cover seal -1- toward front.
 - Carefully remove plenum chamber cover -2- upward.

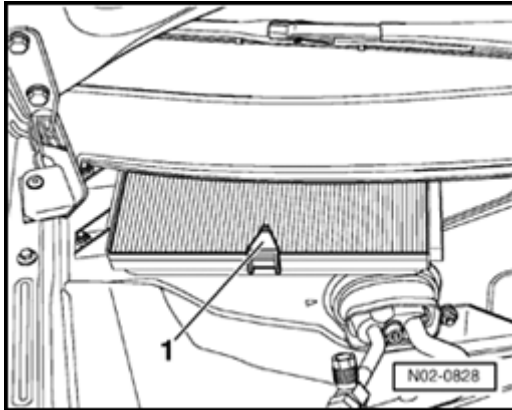

- A** - Pull up retainer -1- upward.
- Push filter element upward and pull out toward front.

Note:

Observe local disposal regulations of filter elements.

Installing

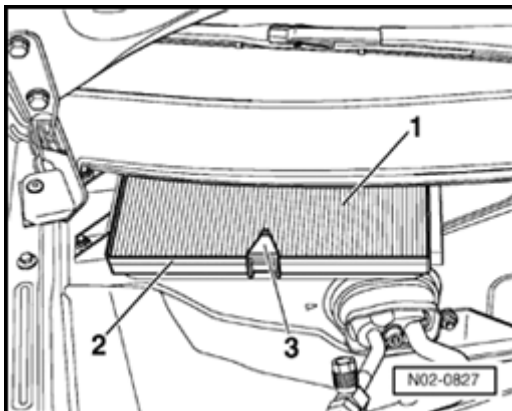

- A** - Insert new filter element -1- into frame -2-.

Note:

When installing filter observe installation position.

- Insert retainer -3- and push down to stop.

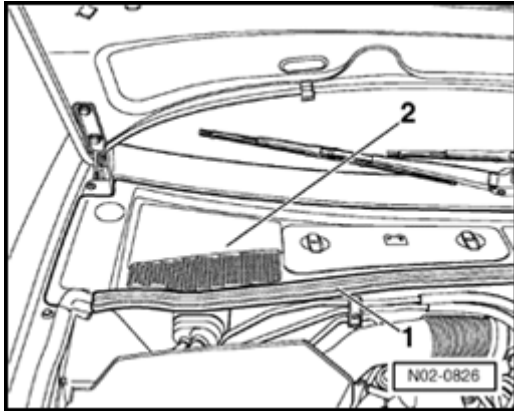

A

- Install plenum chamber cover -2-.
- Push on seal -1- for plenum chamber cover.



Camshaft belt, checking (4-cyl. engine)

Camshaft belt condition, checking

- Open clamps of upper belt cover and remove cover.

- Check condition of camshaft for:
 - ◆ Cracks

 - ◆ Separation of layers (belt body, cords)

 - ◆ Breaks at belt body

 - ◆ Fraying of belt cords

 - ◆ Surface cracks (plastic cover)

 - ◆ Traces of oil or grease

- Also check belt tensioner for wear or damage.

**Note:**

If belt damage is found, the camshaft belt must be replaced to avoid serious engine damage. Replacing the camshaft belt is a separate repair procedure.

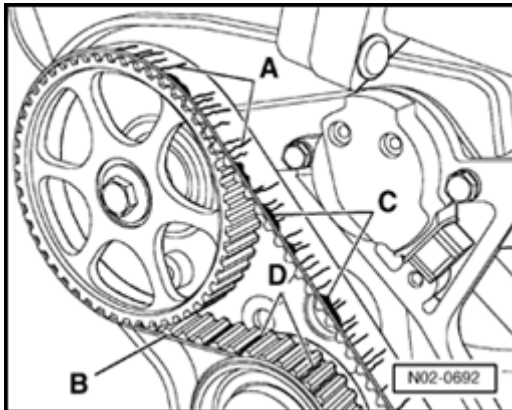

A When checking belt condition, the following is especially important:

A - Cracks at the cover side

B - Chafing marks at the edges of the belt

C - Fraying

D - Cracks at the gear side

Camshaft belt, replacing

⇒ *Repair Manual, Engine Mechanical, Repair Group 13*



Air cleaner, cleaning housing and replacing filter element

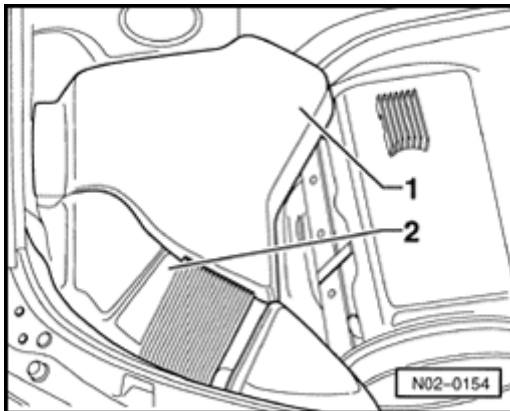

- A**
- Lift up cover -1- (if installed) and remove.

Note:

For some vehicles the cover -1- is bolted down.

- Remove air intake hose -2-.

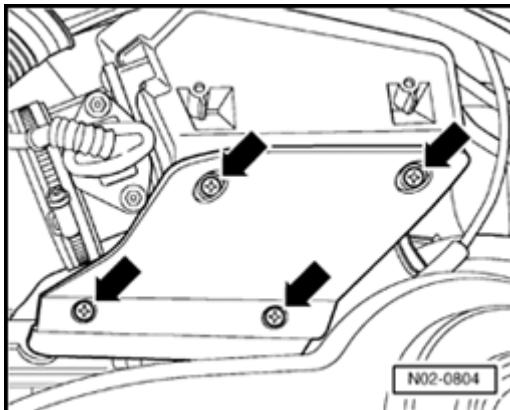

- A**
- Remove screws -arrows- and remove heat shield.

Note:

The heat shield is not installed in all vehicles.



- A**
- Open clamps -1- .
 - Release hose clamp -2- and remove air intake hose.

Note:

For some vehicle the air intake hose does not need to be removed.

- Lift up air cleaner housing upper part or lay aside.

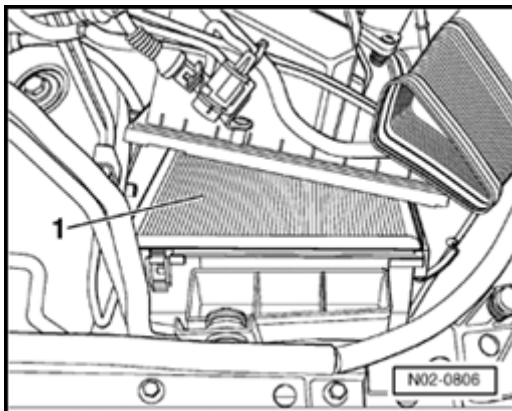

- A**
- Remove old filter insert -1- .

Note:

Observe disposal regulations of filter elements.

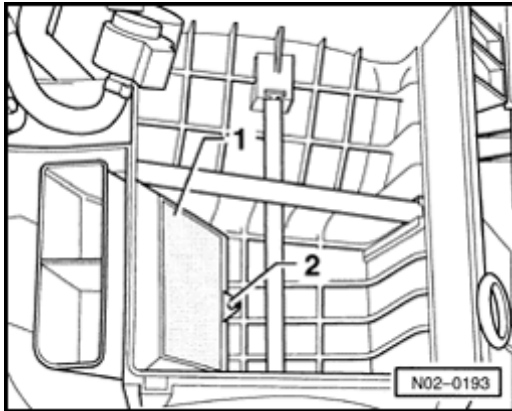

- A** Depending on the model, a screen -1- is installed in lower part close to the air intake channel.

The purpose of the screen is to catch ice or snow during the cold season to prevent clogging of the air cleaner element.

When the screen -1- becomes visible after removing the filter insert, do the following:

- Remove bolt -2- .
- Remove screen -1- from guide and pull up.
- Brush screen and clean with compressed air.
- Insert screen, press down and secure with bolt.

Continuation (with or without screen):

- Clean air cleaner housing and install new filter element.



- A**
- Install upper air cleaner housing and secure with clamps -1- .
 - If necessary install air intake hose and secure with hose clamp -2-.

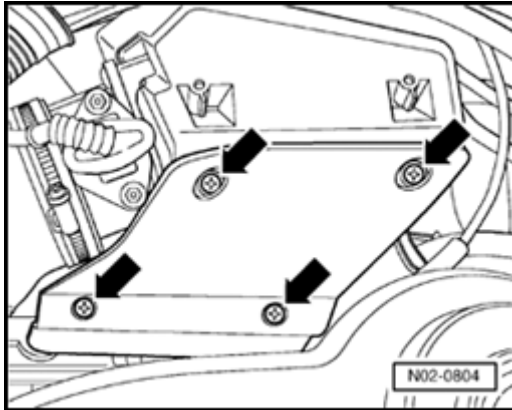

- A**
- If applicable, install heat shield and secure with screws -arrows-.

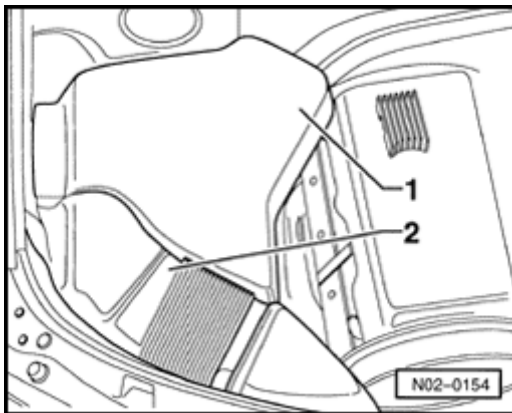

- A**
- Install air intake hose -2-.
 - If applicable, install cover -1-and secure in guides with either clamps or screws.



Automatic transmission, ATF level, checking

Automatic transmission 01V ATF level, checking

Transmission codes are listed on the vehicle data sticker ⇒ [Page 19](#) .

Before checking ATF level, check ATF temperature. There are two methods:

- ◆ with V.A.G 1551 Scan tool ⇒ [Page 121](#)

or with

- ◆ Vehicle Diagnosis, Testing and Information System VAS 5051 ⇒ [Page 125](#) .

Check ATF level as follows:

ATF temperature of automatic transmission, checking with V.A.G 1551 Scan Tool

Special tools and equipment

A

- ◆ V.A.G 1551 Scan Tool

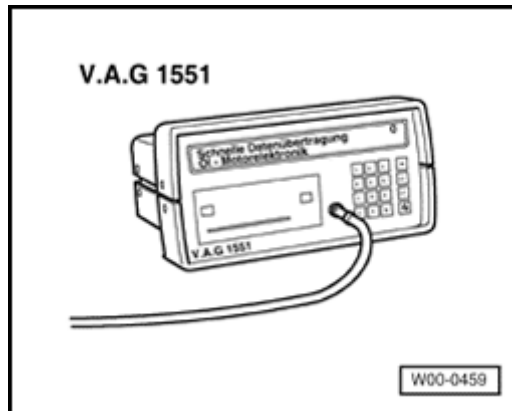

A

- ◆ V.A.G 1551/3 A Adapter cable

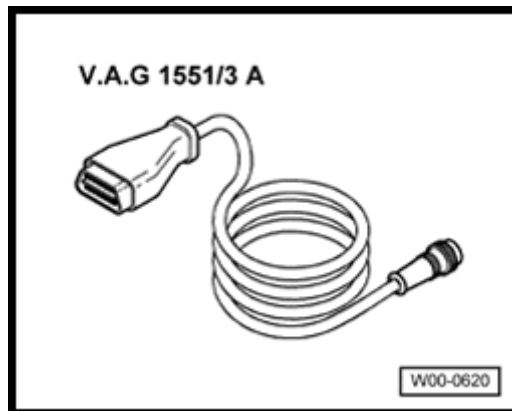

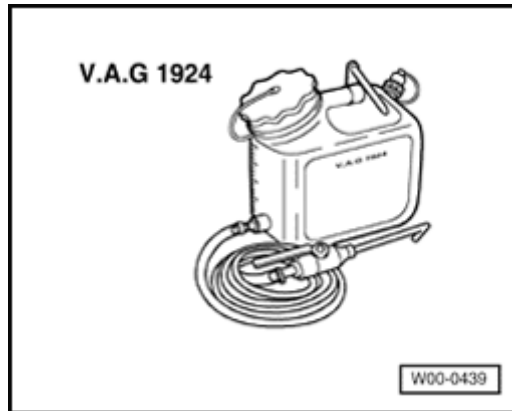

A

- ◆ V.A.G 1924 ATF Filling system

Checking requirements:

- ◆ Transmission not in emergency running mode, ATF temperature not above approx. 30 ° C (86 ° F)
- ◆ Vehicle must be in level position.
- ◆ Selector lever in "P"

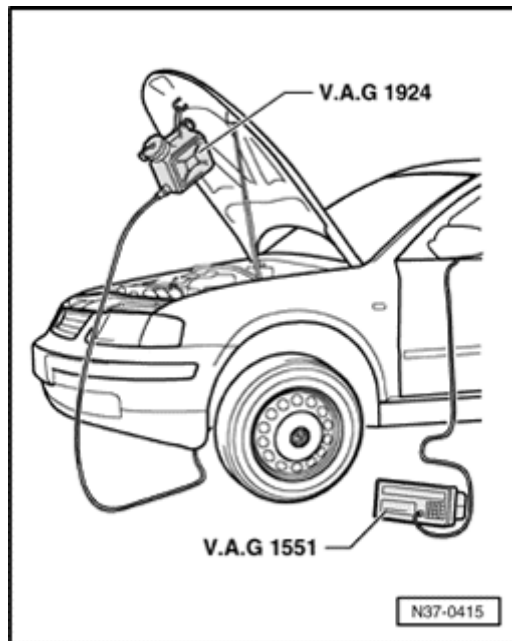

A

- Attach ATF filling system V.A.G 1924 to vehicle.
- Connect V.A.G 1551 scan tool ⇒ [Page 15](#) .
- Start engine and let idle.

			On V.A.G 1551:
V.A.G. On Board Diagnostic	HELP	▲	Indicated on display
1 - Rapid data transfer*			* Shown alternately
2 - Blink code output*			- Press button 1 for function "Rapid data transfer".
Rapid data transfer	HELP	▲	Indicated on display
Input address word XX			- Press buttons 0 and 2 for "Transmission electronics".
Rapid data transfer	Q	▲	Indicated on display
02 Transmission electronics			- Press Q-button to confirm entry..
3B0927156S AG5 01V 1.85VT Rdw D63 →		▲	Indicated on display
Code 00003	WSC 00000		Engine Control Module (ECM) identification, the code and dealer number are shown on the V.A.G 1551 display.
Control module does not answer! HELP		▲	<i>Indicated on display</i>
			- By pressing the HELP-button a list of possible Diagnostic Trouble Codes (DTC) can be printed out.
			- After correcting DTCs, enter address word 02 again for transmission electronics and confirm with Q-button.

3B0927156S AG5 01V 1.85VT Rdw D63 →
Code 00003 WSC 00000

- ↖ Indicated on display
- Press → button.
- Raise vehicle.
- Place drip pan under transmission.

Rapid data transfer HELP
Select function XX

- ↖ Indicated on display
- Press buttons 0 and 8 to select "Read measured value block".

Rapid data transfer Q
08 - Read measured value block

- ↖ Indicated on display
- Press Q-button to confirm entry..

Read measured value block
Enter display group number XXX

- ↖ Indicated on display
- Press buttons 0; 0 and 4 to select "Display group number 004"

Read measured value block Q
Enter display group number 004

- ↖ Indicated on display
- Press Q-button to confirm entry..

Read measured value block 4 →
300 C P 1000 0000

- ↖ Indicated on display
- The first display filed shows the ATF temperature.
- Bring ATF to checking temperature

Specified value: 35 to 45 ° C (95 to 113 ° F)

- Check ATF level ⇒ [Page 129](#) .



Oil temperature of automatic transmission, checking with Vehicle Diagnosis, Testing and Information System VAS 5051

Special tools and equipment

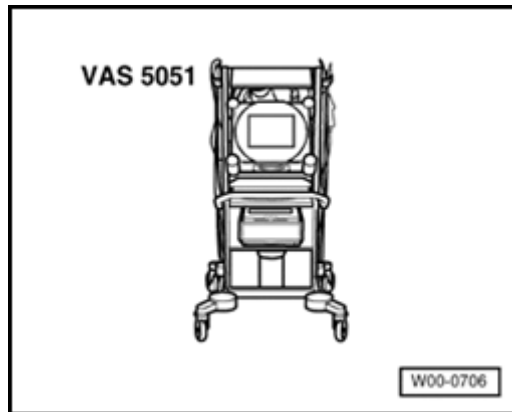

A

- ◆ VAS 5051 Vehicle Diagnosis, Testing and Information System
- ◆ VAS 5051/3 Adapter cable

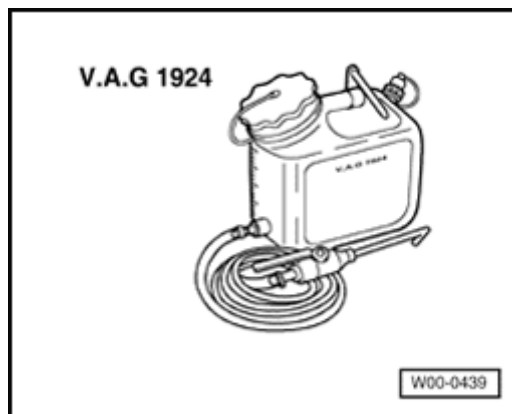

A

- ◆ V.A.G 1924 ATF Filling system



Checking requirements

- ◆ Transmission not in emergency running mode, ATF temperature not above approx. 30 ° C (86 ° F)
- ◆ Vehicle in level position
- ◆ Selector lever in "P"

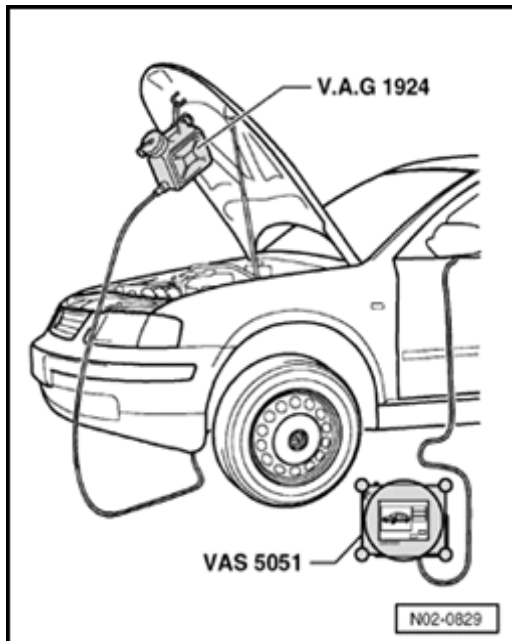

A

- Attach ATF filling system V.A.G 1924 to vehicle.
- Connect Vehicle Diagnosis, Testing and Information System VAS 5051 ⇒ [Page 16](#) .
- Start engine and let idle.

↖ Indicated on display

Select function

- On display press button "On Board Diagnostics" -arrow-.

Note:

If no functions are shown on display:

⇒ *Operating instructions for Vehicle Diagnosis, Testing and Information System VAS 5051.*

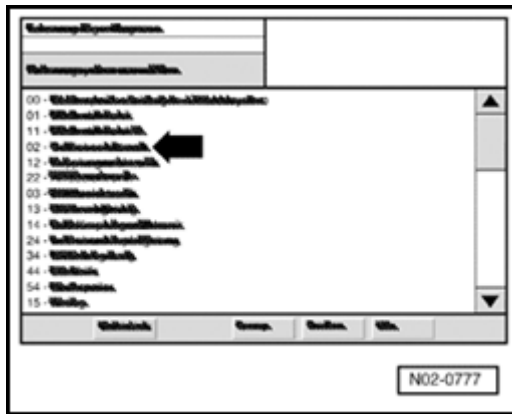

⚠ Indicated on display

Select vehicle system

- On display press on button "02 - Transmission electronics" -arrow-.

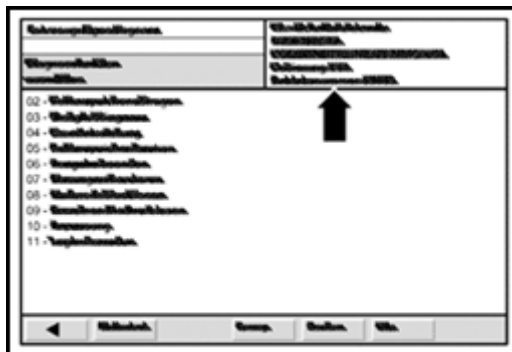

⚠ Indicated on display

The control module identification and code are shown -arrow-.

- Raise vehicle.
- Place drip pan under transmission.

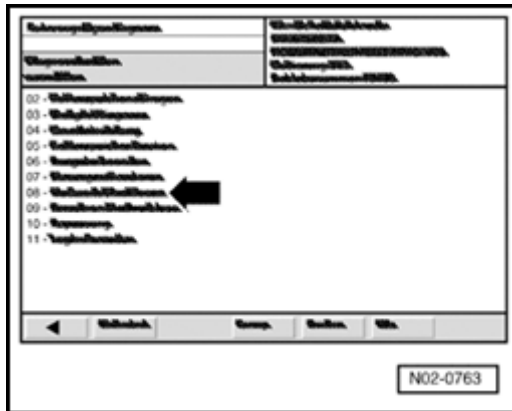

A Indicated on display

- On display press button "08 - Read measured value block" -arrow-.

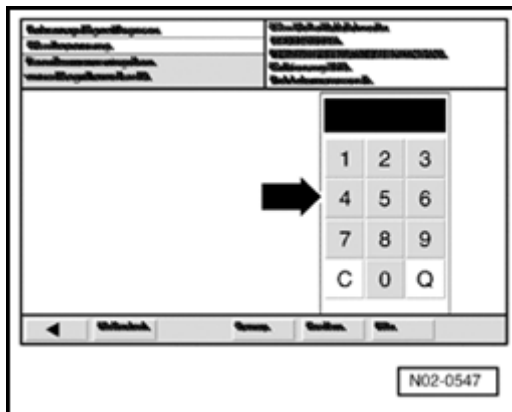

A Indicated on display

- On display press on display group number block -arrow- 004 (with 004 "Display group number 004" is selected).
- On display group number block confirm entry by pressing Q-button.

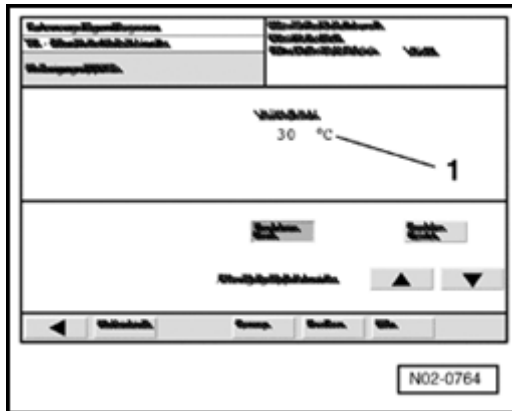

- A Indicated on display
- The display filed -1- shows the ATF temperature.
- Bring ATF to checking temperature
Specified value: 35 to 45 ° C (95 to 113 ° F)
- Continue with test only when required temperature is reached.
- Check ATF level.

ATF level, checking

Special tools and equipment

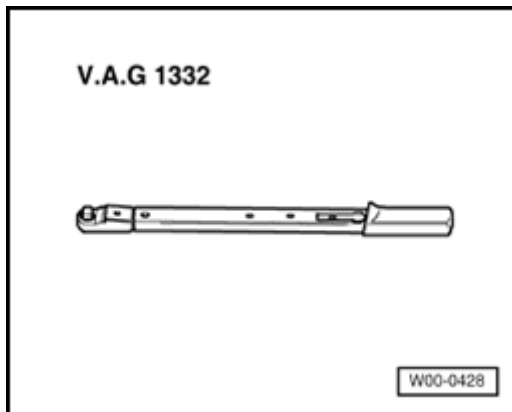

- A ♦ V.A.G 1332 Torque wrench 40 - 200 Nm (30 to 148 ft lb)

Test temperature: 35 ° C to 45 ° C (95 to 113 ° F)

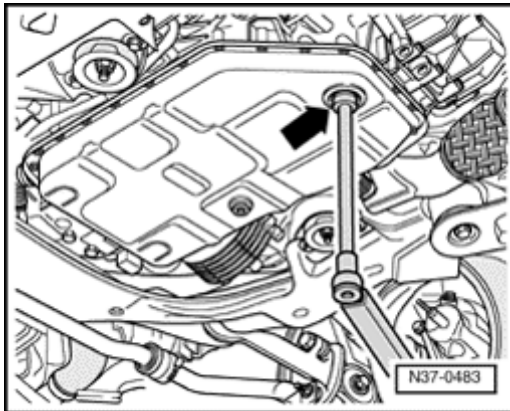

- A** - Remove plug -arrow-to check ATF level in oil pan.

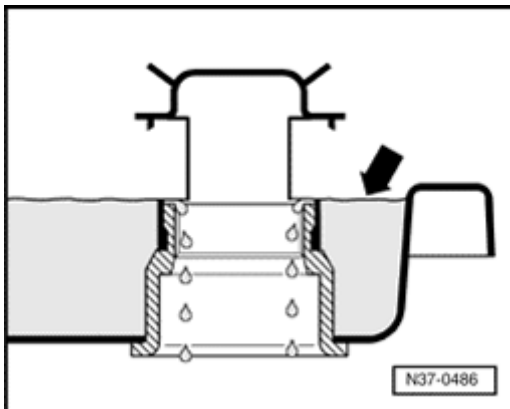

- A** ATF in the over-flow tube 2- will run out.

If ATF drips from plug hole:

No ATF needs to be added.

- Install plug for ATF check with new seal and tighten plug to 80 Nm (59 ft lb). This ends the ATF level check.
- End output at 1551 or 5051 and disconnect Data Link Connector (DLC).



If ATF runs out of plug hole from the overflow pipe only:

Top up ATF

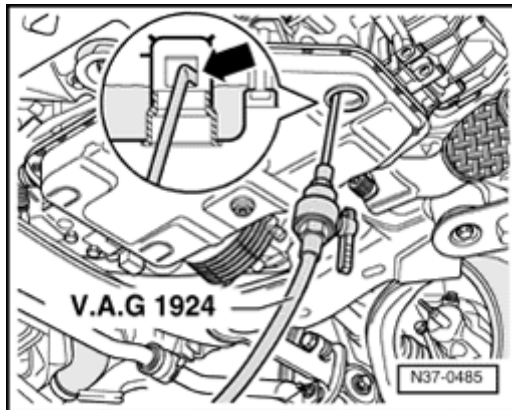

- A - Insert filler hose of 1924 into opening -arrow- of cap. Do not push cap up.

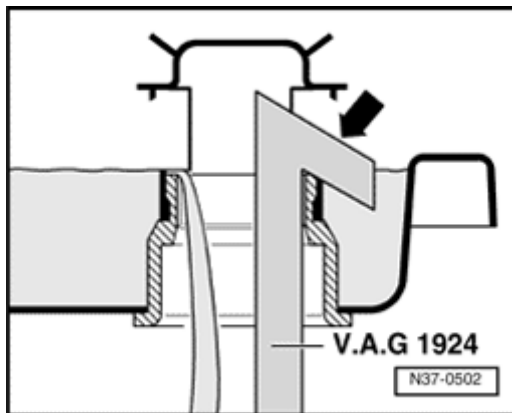

- A - With V.A.G 1924 -arrow- fill ATF until ATF drip from check hole.

Note:

Too much or too little ATF affects the function of the transmission.

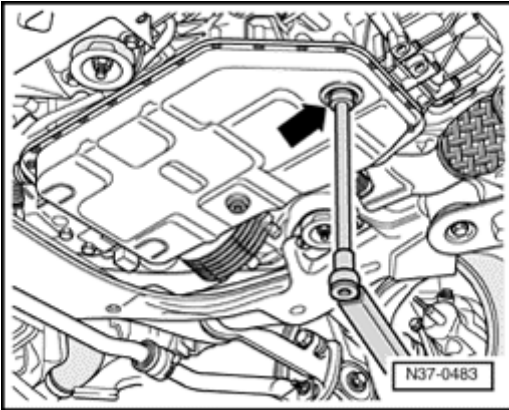
**A**

- Install plug for ATF check with new seal and tighten to 80 Nm (59 ft lb).
- End output with 1551 or 5051 and disconnect Data Link Connector (DLC).



Power steering fluid level, checking

With fluid cold:

- With engine not running, move front wheels in straight-ahead position.

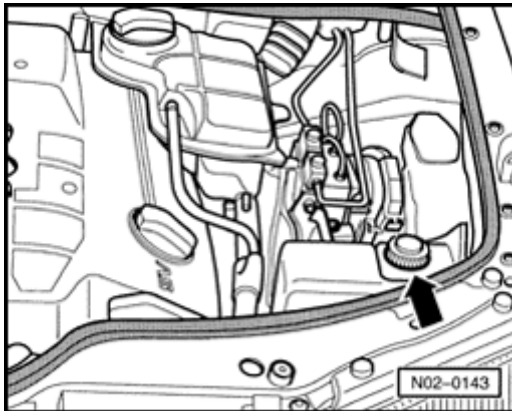

A

- Remove reservoir cap -arrow- with dipstick.
- Clean dipstick with clean cloth.
- Screw cap on hand-tight and remove again.

Note:

Screw cap fully in to get an accurate fluid level reading.

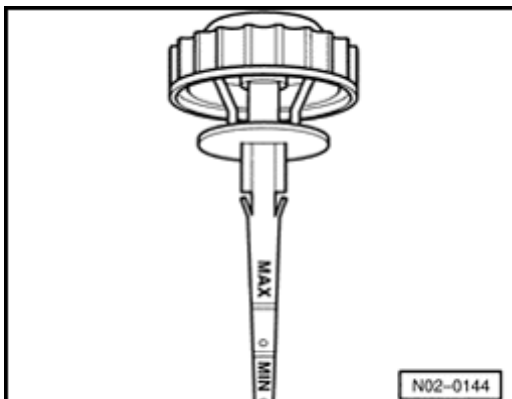

A

- Fluid level must be in area of MIN mark (up to 2 mm above or below mark).

Notes:

- ◆ *If fluid level is above the mark, some fluid must be siphoned off.*
- ◆ *If the fluid level is below the specified level, check the hydraulic system for leaks (repair procedure). It is not sufficient just to add fluid.*
- ◆ *If no leaks are detected, top up with hydraulic fluid G 002 000.*



- Reinstall cap and tighten by hand.

Hydraulic fluid at operating temperature from about 50° C (122° F):

- Start engine and move front wheels into straight-ahead position

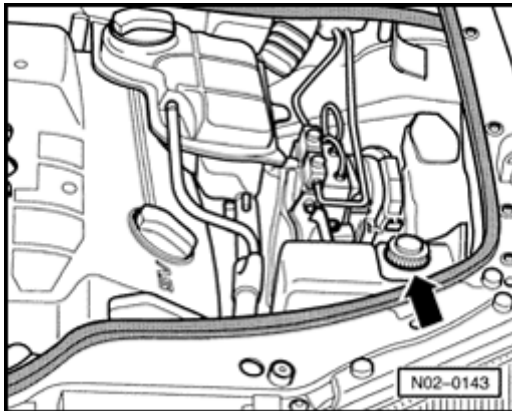

A

- Remove reservoir cap -arrow- with dipstick.
- Clean dipstick with clean cloth.
- Screw cap on hand-tight and remove again.

Note:

Screw cap fully in to get an accurate fluid level reading.

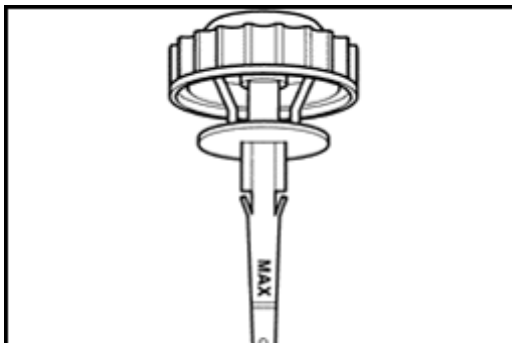

A

- Check fluid level. It must be between MIN and MAX markings.

Notes:

- ◆ *If the fluid level is above the MAX mark, siphon fluid off.*
- ◆ *If the fluid level is below the MIN mark, check the hydraulic system for leaks (repair procedure). It is not sufficient to simply fill the system with hydraulic fluid. If no leaks are found, top up with-hydraulic fluid G 002 000.*

- Install reservoir cover and tighten by hand.



Brake fluid, changing

Notes:

When changing brake fluid use only brake filler and bleeder unit VAS 5234.

Special tools and equipment

A

- ◆ VAS 5234 brake filling and bleeding equipment (for all vehicles)

Only use new brake fluid conforming with US Standard FMVSS 116 DOT 4.





WARNING!

- ◆ *Do not let brake fluid come in contact with fluids containing mineral oil (oil, gasoline, cleaning fluid). Mineral oil will damage seals in the brake system which may cause brake failure.*
- ◆ *Brake fluid is poisonous. Do not ingest brake fluid. Wash thoroughly with soap and water if brake fluid comes in contact with skin.*

CAUTION!

- ◆ *Do not let brake fluid come in contact with paint to prevent damage.*
- ◆ *Brake fluid absorbs moisture from the surrounding air and must always be stored in air-tight containers.*
- ◆ *Don't pollute. Follow local rules when disposing of old brake fluid.*

Vehicles up to m.y. 1999

Follow operator's instructions for VAS 5234.

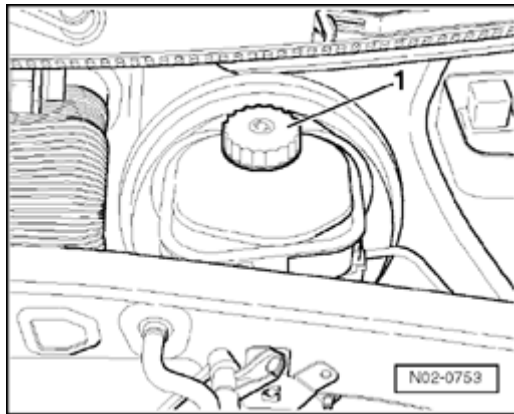

- A** - Remove cap -1- from brake fluid reservoir.

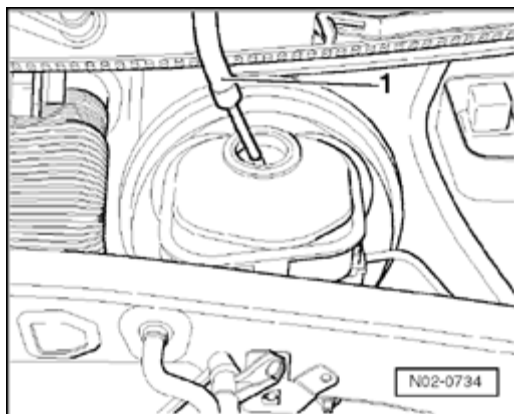

- A** - Using suction hose -1- from VAS 5234 remove as much brake fluid from the reservoir as possible.

Note:

Note that after extracting brake fluid, no brake fluid runs back through the screen. The brake fluid level must be at the underside of the screen.



Vehicles from m.y. 2000

Follow operator's instructions for VAS 5234!

For vehicles with ABS/EDL/ASR/ESP please observe the following:

CAUTION!

- ◆ ***When changing brake fluid using VAS 5234 maintain a fill pressure of 2 bar***
- ◆ ***Be sure to maintain a minimum system pressure of 2 bar***

Set brake fluid pressure on VAS 5234 to 2 bar and follow operating instructions.

A

- Remove cap -1- from brake fluid reservoir.

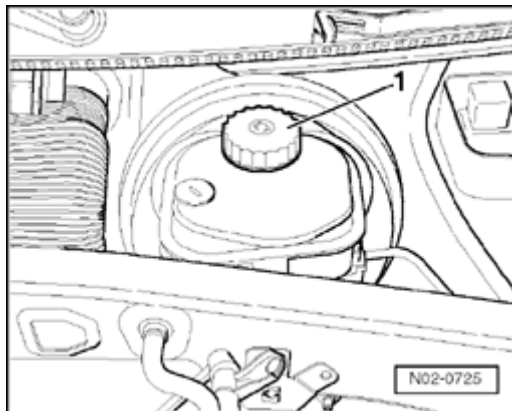

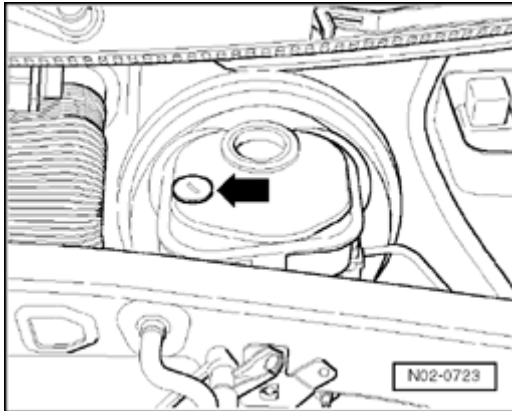

- A**
- Remove cap -arrow- of brake fluid reservoir by turning.

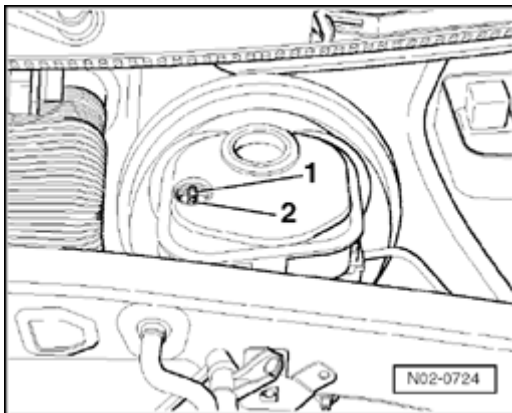

- A**
- Connect suction hose of VAS 5234 to tube -1- of brake fluid reservoir.
 - With suction hose of VAS 5234, extract as much brake fluid as possible from reservoir.
 - Remove suction hose.
 - Connect suction hose of VAS 5234 to tube -2- of brake fluid reservoir.
 - With suction hose of VAS 5234, extract as much brake fluid as possible from reservoir.
 - Remove suction hose.
 - Reinstall cap in brake fluid reservoir.

Continued for all vehicles:

CAUTION!

Don't pollute. Follow local rules when disposing of old (used) brake fluid.

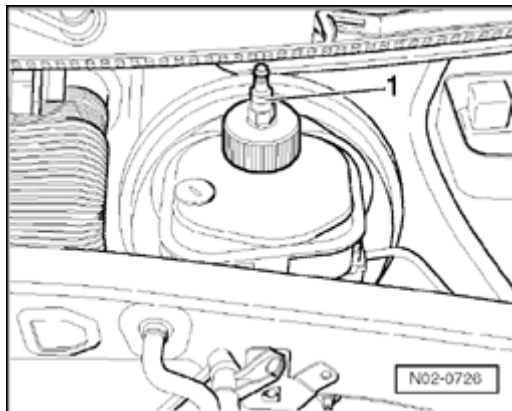

- A** - Install adapter -1- on brake fluid reservoir.

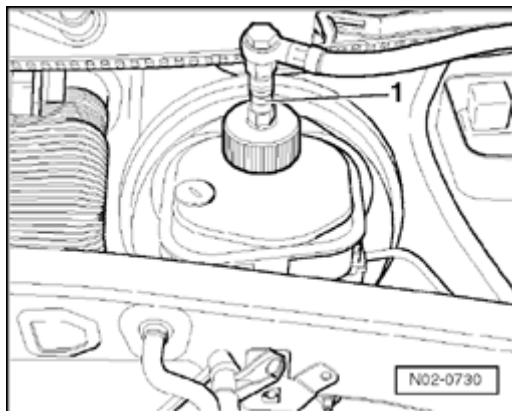

- A** - Connect filler hose -1- of VAS 5234 to adapter.



Vehicles with manual transmission:

- Remove cap off bleeder screw for clutch slave cylinder.

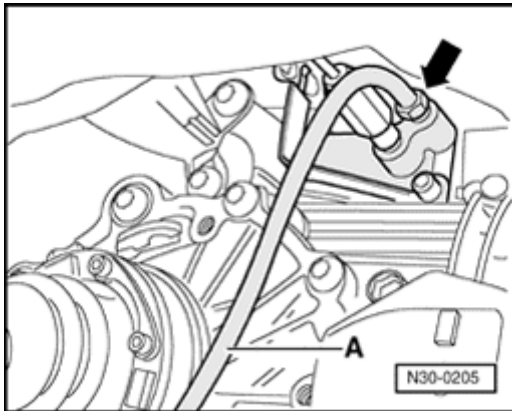

A

- Attach bleeder hose -A- of bleeder bottle to bleeder screw of clutch slave cylinder -arrow-. Open bleeder screw and let approx. 0,1 liter flow out. Close bleeder screw and reinstall cap.
- Activate clutch pedal several times.

Continued for all vehicles:

- Remove caps for bleeder screws at all brake calipers.

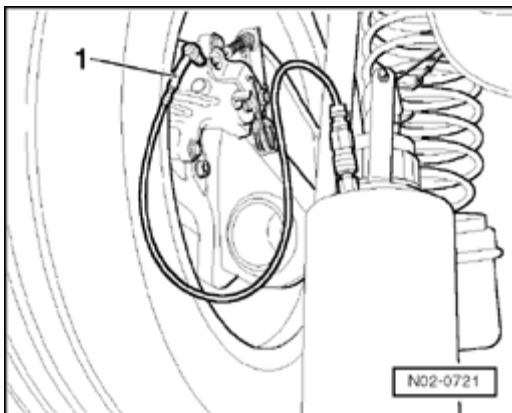

A

- Starting with left rear, attach bleeder hose -1- of bleeder bottle to bleeder screw. Open bleeder screw and let applicable amount of brake fluid flow out (see table on next page). Close bleeder screw.
- Repeat procedure on other side at rear.

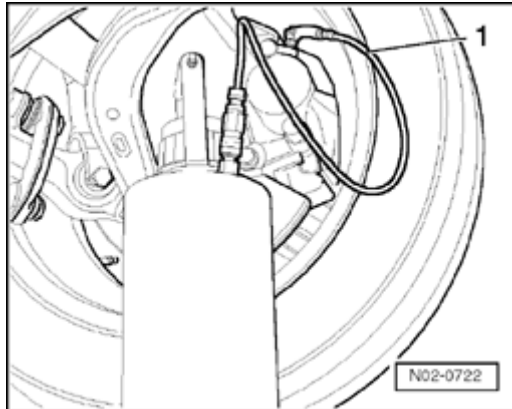

A

- At front right caliper, attach bleeder hose -1- of bleeder bottle. Open bleeder screw and let applicable amount of brake fluid flow out (see following table). Close bleeder screw.
- Repeat procedure on the other side at front.

Table: Sequence and brake fluid amount

Sequence: Brake fluid that must flow from caliper

Brake caliper

	Up to m.y. 1999	From m.y. 2000
right rear	0.4 to 0.5 liter (0.4 to 0.5 qt)	0.2 liter (0.21 qt)
left rear	0.4 to 0.5 liter (0.4 to 0.5 qt)	0.2 liter (0.21 qt)
right front	0.4 to 0.5 liter (0.4 to 0.5 qt)	0.2 liter (0.21 qt)
left front	0.4 to 0.5 Liter (0.4 to 0.5 qt)	0.2 liter (0.21 qt)
Total amount ¹⁾	2 liter	1 liter

(2.1 qt)

(1.05 qt)

1) Including suctioned-off brake fluid from brake fluid reservoir and change quantity from clutch slave cylinder.

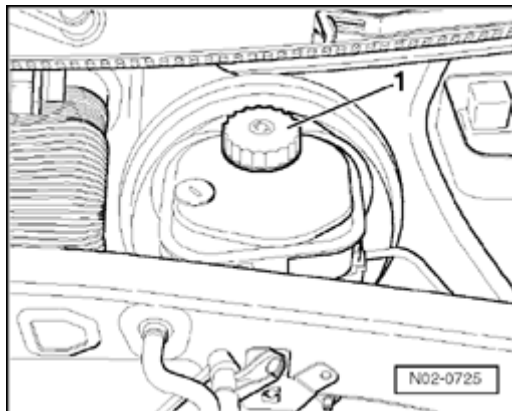

- Re-install caps on bleeder screws on calipers.
- Set filling lever of VAS 5234 to position -B- (see operators manual).
- Remove filling hose from adapter.
- Remove adapter from brake fluid reservoir.
- Check brake fluid level, correct if necessary.

**A**

- Install cap -1- of brake fluid reservoir.
- Remove brake pedal depressor.
- Check pedal pressure and free play.

Free play must not be more than $\frac{1}{3}$ of brake pedal travel.



Brake fluid level (depending on brake pad wear), checking

Only use new brake fluid conforming with US Standard FMVSS 116 DOT 4.

WARNING!

- ◆ *Do not let brake fluid come in contact with fluids containing mineral oil (oil, gasoline, cleaning fluid). Mineral oil will damage seals in the brake system which may cause brake failure.*
- ◆ *Brake fluid is poisonous. Do not ingest brake fluid. Wash thoroughly with soap and water if brake fluid comes in contact with skin.*

CAUTION!

- ◆ *Do not let brake fluid come in contact with paint to prevent damage.*
- ◆ *Brake fluid absorbs moisture from the surrounding air and must always be stored in air-tight containers.*

- ◆ ***Don't pollute. Follow local rules when disposing of old (used) brake fluid.***



Pre-delivery inspection:

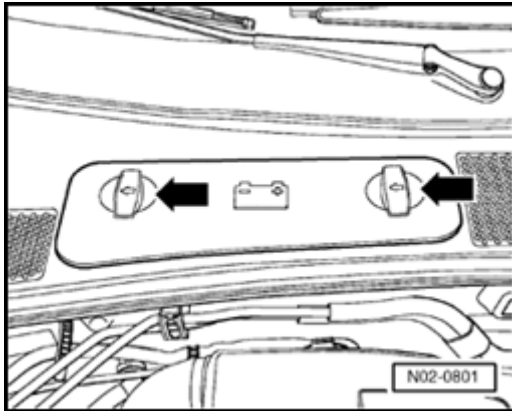

A

- For vehicles manufactured after 10.00, push battery cover to the left -arrows- and remove.

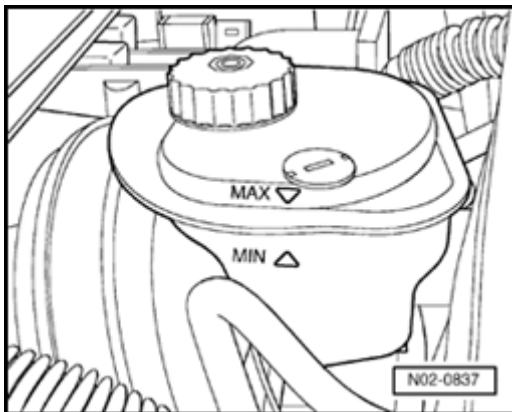

A

- Through hole of battery cover and using flashlight, read brake fluid level in brake fluid reservoir. At time of pre-delivery inspection, brake fluid level must be at MAX mark.

Note:

To prevent the brake fluid from overflowing from the reservoir, the level must not over the MAX mark.

Inspection Service:

Brake fluid level must always be evaluated depending on brake pad wear. During operation of the vehicle, the brakes are automatically readjusted depending on wear of the brake pads. Because of the adjustment, brake fluid level will be slightly lower as a result.



- ◆ With brake fluid at MIN mark or slightly above, topping up brake fluid is not necessary when wear limit of brake pads has been almost reached.

- ◆ When brake pads are new or if there is still enough brake lining left, the brake fluid level must be between MIN and MAX marks.

- ◆ If brake fluid level is below MIN mark, check brake system (repair procedure), before adding brake fluid.

Battery connections, checking

Special tools and equipment

A

- ◆ V.A.G 1331 Torque wrench 5 to 50 Nm (44 in. lb to 30 ft lbs)

Note:

Tight battery connections assure trouble-free battery function and long service life.

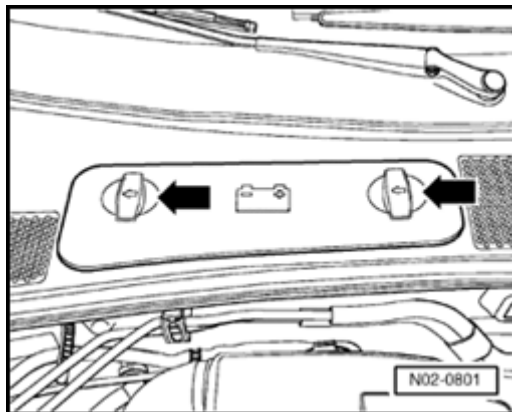
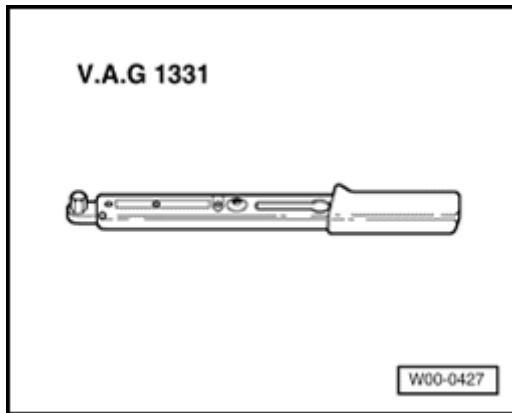

A

- Push battery cover to left -arrows- and lift cover off.

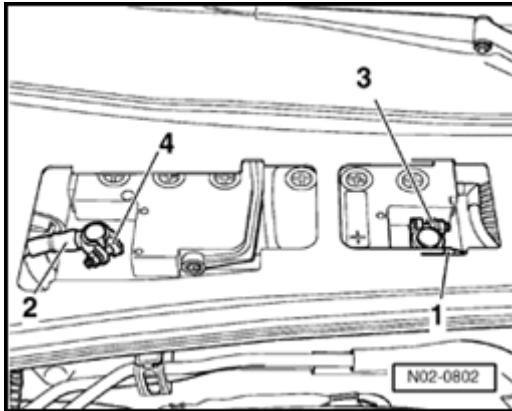

A

- By manually moving battery plus (B+) cable -1- and ground (GND) cable -2- check whether battery connections -3- and -4- are tight.

WARNING!

If plus (B+) connection is loose: To prevent personal injury and battery damage, disconnect ground (GND) cable first before attempting to remove or tighten plus connection.

If battery plus (B+) connection is not tight:

Notes:

- ◆ *Before disconnecting battery, obtain radio anti-theft code.*
- ◆ *When reconnecting battery, activate radio, adjust clock, activate power windows, etc. (see repair manual or owner's manual).*

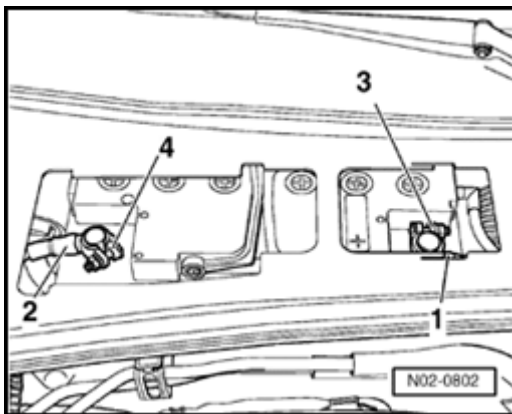

A

- First disconnect ground (GND) cable connection -4- on battery.
- Tighten battery plus (B+) connection -3- with 5 Nm (44 in. lb).
- Reconnect ground connection -4- on battery and tighten to 5 Nm (44 in. lb).

If ground connection on battery is not tight:

- Tighten ground connection -4- on battery to 5 Nm (44 in. lb).



Battery, checking

Special tools and equipment

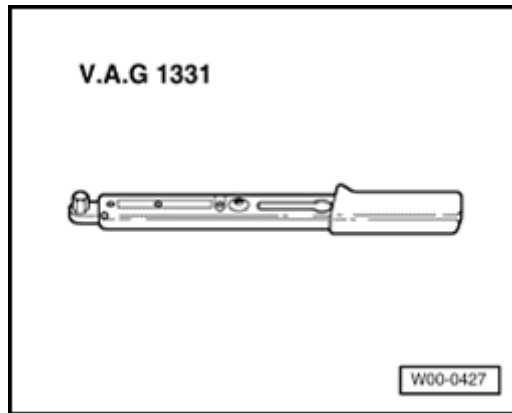

A

- ◆ V.A.G 1331 Torque wrench 5 - 50 Nm (44 in. lb to 37 ft lb))

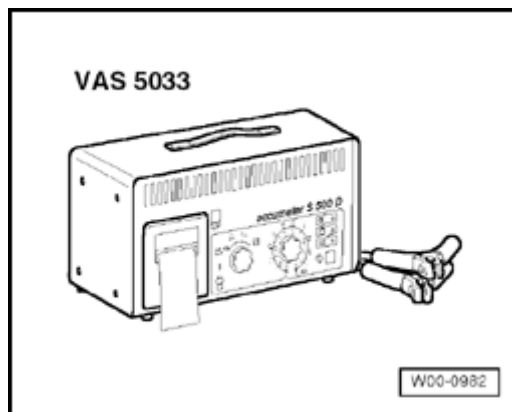

A

- ◆ VAS 5033 Battery tester

or

- ◆ VAS 5096 Battery tester

or

- ◆ VAS 5097 Battery tester with printer

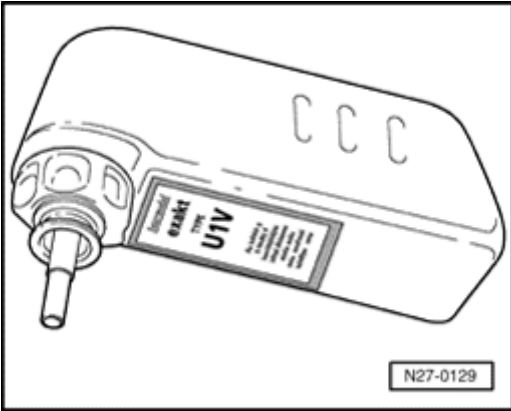

A ♦ VAS 5045 battery filling bottle

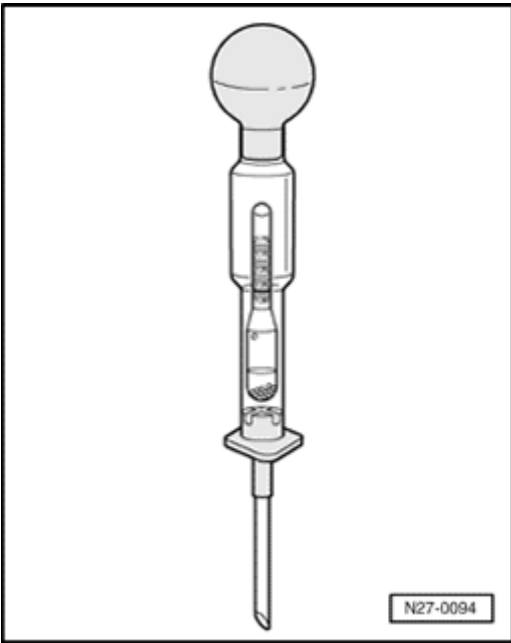

A ♦ Commercially available hydrometer



Pre-delivery inspection (battery with charge indicator "magic eye")

Perform visual inspection ⇒ [Page 152](#) and battery check using "magic eye" ⇒ [Page 153](#) .

Pre-delivery inspection (battery without charge indicator"magic eye")

Perform visual inspection ⇒ [Page 152](#) and battery load test ⇒ [Page 154](#) .

Inspection Service (battery with charge indicator"magic eye")

Perform visual inspection ⇒ [Page 152](#) and battery load test with "magiceye" ⇒ [Page 153](#) .

Inspection Service (battery without charge indicator"magic eye")

Perform visual inspection ⇒ [Page 152](#) and electrolyte level check ⇒ [Page 157](#) . If distilled water is added, also perform battery load test ⇒ [Page 154](#) .



Visual check (all batteries)

- Check battery housing for damage.

If battery housing is damaged, electrolyte (battery acid) can leak.

- Check battery pole (battery cable connections) for damage.

If battery poles are damaged, the electrical connection for the cable connections cannot be assured. Such condition could cause cable burn and damage to the electrical system.

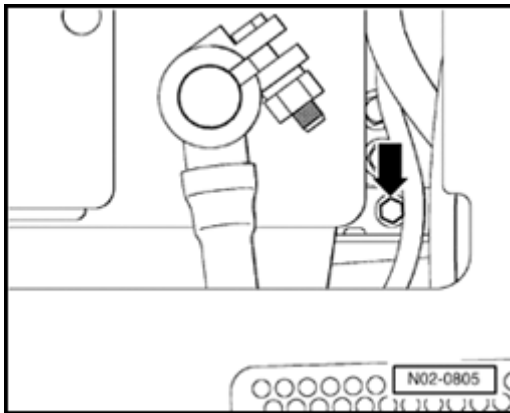
**A**

- Check battery firm seating and attachment. Tighten bolt -arrow- at hold-down bracket with 22 Nm (16 ft lb).

If battery is not firmly secured, the following danger exist:

- ◆ Shortened service life of battery caused by vibration.
- ◆ Damage to battery housing caused by hold-down bracket which may lead to damage to the battery housing and electrolyte leaks resulting in extensive damage.
- ◆ Reduced crash safety.



Battery, checking (battery with charge indicator "magic eye")

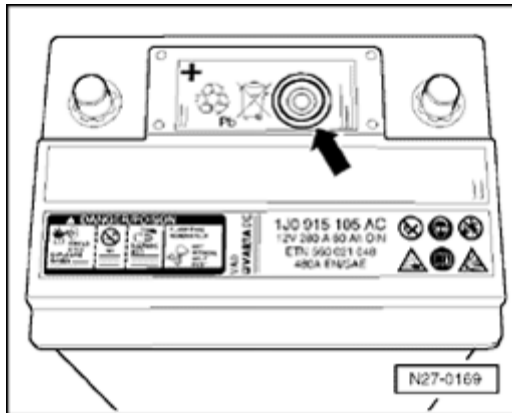

A The "magic eye" provides information about the electrolyte level and state of the battery charge.

- Before performing visual checks, carefully and slightly knock magic eye with handle of a screwdriver.

Air bubbles that could affect the function of the magic eye are dispersed.

The color display of the magic eye will also be clearer.

Notes:

The "magic eye" can be at different locations on the battery.

Three color displays are possible:

- ◆ *Green: → battery charge is OK.*
- ◆ *Black → no charge or too little charge (repair required)*
- ◆ *No color or yellow → critical electrolyte level, distilled water needs to be added ⇒ [Page 156](#) . After adding distilled water perform battery load test ⇒ [Page 154](#) .*

**Note:**

If the battery is older than 4 years and the magic eye displays no color or yellow, the battery must be replaced. Get customer OK first.

Battery load test

- Switch ignition off.

- Attach test lead tongs to battery poles.

⇒ *Operator's guide of battery tester*

The tongs must make good contact with battery poles.

Load current depends on battery capacity and must be adjusted on the tester.

⇒ *Operating instructions for battery tester.*

- Perform battery load test according to operating instructions of battery tester and compare test

result with table.

Table:

Battery tester display	Pre-delivery inspection	Inspection Service
battery very good	battery OK	battery OK
battery good	recharge battery ¹⁾	battery OK
battery poor	replace battery	replace battery ²⁾
battery faulty	replace battery	replace battery ²⁾

1) After recharging the battery, again perform a battery load test. If after recharging the battery the result is again "battery good", replace battery.

2) Replace battery after getting OK from customer.

Notes:

Regarding battery load test:

Because of the high load the battery is

- ◆ *subjected to during the load test, the battery voltage is lowered.*
- ◆ *If the battery is OK, the voltage only goes down to the minimum voltage specification.*
- ◆ *If the battery is faulty or not charged enough, the battery voltage drops quickly below the minimum voltage specification.*
- ◆ *After the test, this low voltage remains steady over a longer time before the voltage slowly increases.*



Filling with distilled water (battery with charge indicator "magic eye")

To avoid contamination of the electrolyte - which leads to accelerated self-discharging - use only distilled water when the electrolyte level is too low.

- Peel off foil over battery caps.
- Remove battery caps.
- Using battery filling bottle VAS 5045, fill with distilled water to max. marking.

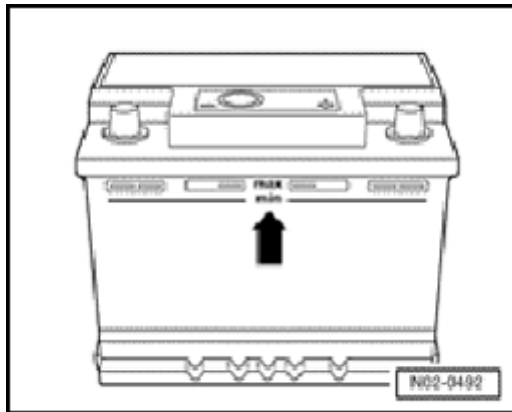

Notes:

- ◆ *The design of the filler tube of battery filler bottle VAS 5045 prevents overfilling of the battery cells. When the max. mark is reached, the flow of distilled water to the cells is interrupted.*
 - ◆ *When the electrolyte level is too low (below the min. mark), the battery loses capacity (loses performance) caused by drying of the cell plates. If the cell plates are not covered by electrolyte, the plates and plate bridges start to corrode causing the function of the battery to diminish. After a while the battery does no longer function.*
 - ◆ *When the electrolyte level is too high (above the max. mark) the electrolyte may leak out and cause damage to components in the engine compartment.*
- Install battery caps.



Electrolyte level, checking (battery without charge indicator "magic eye")

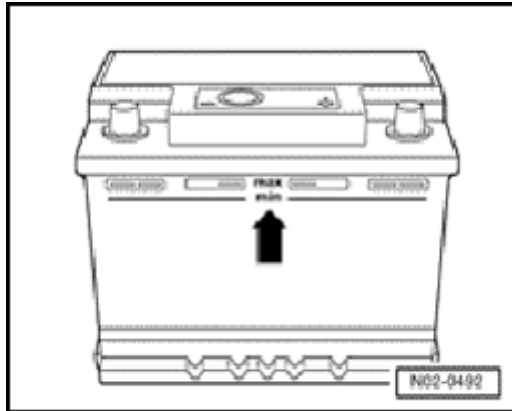

- Markings -arrow- on battery housing

Note:

The correct electrolyte level is very important for long service life of the battery.



Electrolyte level too low

Notes:

- ◆ *When the electrolyte level is too low (below the min. mark), the battery loses capacity (loses performance) caused by drying of the cell plates. If the cell plates are not covered by electrolyte, the plates and plate bridges start to corrode causing the function of the battery to diminish. After a while the battery no longer functions.*
 - ◆ *To avoid contamination of the electrolyte, use only distilled water if it is necessary to increase the level.*
- Remove battery caps.
 - With battery fill bottle VAS 5045 add distilled water to bring level to the max. mark.

Note:

The design of the filler tube of battery filler bottle VAS 5045 prevents overfilling of the battery cells. When the max. mark is reached, the flow of distilled water to the cells is interrupted.

- Install battery caps.



Electrolyte level too high

Note:

If the electrolyte level is too high (above the max. mark), the electrolyte can leak out and cause severe damage to components in the engine compartment.

- Remove battery caps.

If the electrolyte level is too high (battery is overfilled) and the electrolyte level is above the inside electrolyte level mark (plastic bridge):

- Remove electrolyte with a hygrometer (⇒ illustration) until level has reached max. mark or plastic bridge.

Note:

Don't pollute! Dispose of electrolyte according to local regulations.

- Re-install battery caps.

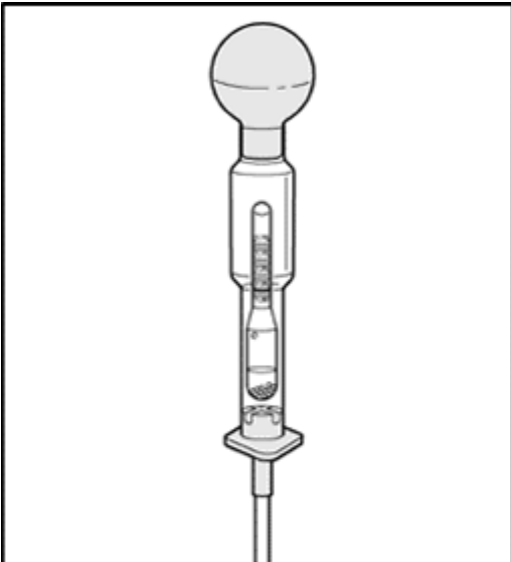



Headlight adjustment, checking

Special tools and equipment

- ◆ VAS 5107 Hella Universal Beamsetter IV Also, see Instruction Manual for Hella Beamsetter Series IV for additional instructions and diagrams.)

Basically all procedures describing headlight adjustments and checks apply for all countries, however, check with local authorities for adjustment requirements.

Requirements for checking and adjusting:

- ◆ Tire pressure must be OK.
- ◆ Headlight lenses must not be damaged or dirty.
- ◆ Reflectors and bulbs OK.
- ◆ Vehicle must be properly loaded.

Vehicle must be loaded with one person on the

driver's seat, weighing 75 kg (165 lb), otherwise vehicle must be empty (curb weight)

The curb weight is the weight of the vehicle ready to be operated with filled fuel tank (at least 90 % filled), including the weight of all equipment usually carried in the car such as spare wheel, tools, car jack, fire extinguisher, etc.



If the fuel tank is not at least 90% full, adjust the weight as follows:

- Read fuel level from fuel gauge. Calculate additionally needed weight using table. Place extra weight in luggage compartment.

Tank filling table

Fuel level according to fuel gauge	Additional weight in luggage compartment
1/4	45 kg (99 lb)
1/2	30 kg (66 lb)
3/4	15 kg (33 lb)
full	0

Example:

If the fuel tank is half full, place a weight of 30 kg (66 lb) in the luggage compartment.

Note:

For additional weight use containers filled with water. A container filled with 5 liters (1.3 gal) of

water weighs approx. 5kg (11 lb).

- Move vehicle back and forth for 1 meter (3 to 4 feet) or bounce front and rear of vehicle several times up and down to settle suspension.

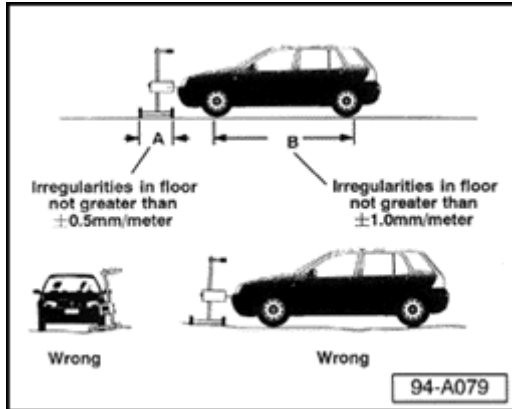
**A**

- Position vehicle on a flat floor surface that meets following (ISO 10640) specifications:
 - ◆ 0.5 mm or less slant from front wheel to back wheel of Beamsetter -A-.
 - ◆ 1 mm or less slant per meter for length of vehicle -B-.
- Clean headlight lenses.
- Adjust vehicle tire pressure to specifications.



Driver's side headlight, setting low beam alignment

- Move Beamsetter into position in front of vehicle so it is aligned with vehicle and Beamsetter box is 30 to 70 cm (12 to 28 in.) from driver's side headlight.
- Switch headlights ON in low beam position.
- Align Beamsetter box so it is centered on headlight (align vertically then horizontally).

Notes:

- ◆ *Use arrows on Beamsetter box as a guide.*
- ◆ *You may want to use a straight edge or tape measure, because alignment must be within 3 cm (1.2 in.) of headlight center.*
- Without moving Beamsetter, slide Broad-band sight toward center of vehicle (Broad-band sight can also be moved up and down for a better position).

Use Broad-band sight to make final alignment of Beamsetter box to vehicle by:

- Loosening hand-wheel that locks column in place.
- Sighting down through slit in Broad-band sight and rotating Beamsetter box and column until two similar points on vehicle are aligned.

**Note:**

Try using corners of headlight housings or two screws that are the same height and as far apart as possible on the vehicle.

- Carefully tighten hand wheel without changing Beamsetter position.
- Find correct State or Province Inclination % specification for low beam adjustment (if there is no local specification, use 0.7%).

Note:

DO NOT use inclination % molded into plastic of headlight housing near headlight adjustment screws; it is for Europe only! ⇒ [Page 165](#) and page ⇒ [Page 167](#) for location of headlight adjuster screws).

- Set Beamsetter "Scaled wheel" to proper low beam inclination %.
- Adjust height (vertical) alignment first. Turn headlight height adjuster screw to align upper edge of flat portion of beam with center horizontal line of grid on Beamsetter pattern

screen.

Headlights, adjusting (vehicles up to production date 09.00)

Headlights, adjusting (vehicles from production date 10.00) ⇒ [Page 167](#)

Note:

When adjusting the low beams, the high beams are also automatically adjusted.

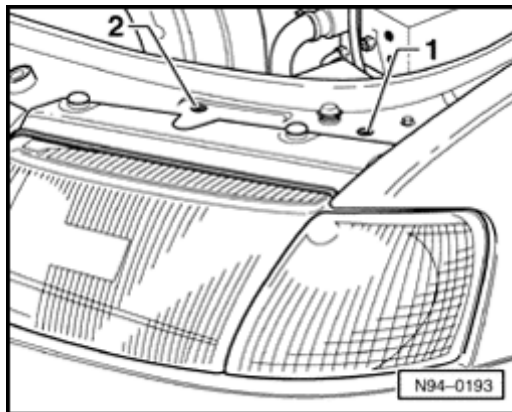

A Headlight, (left):

- 1 - Side adjustment
- 2 - Height adjustment

The adjustment screws for the right headlight are in reversed position.

- Guide Phillips screwdriver or socket head wrench through hole in lock carrier.
- Turn adjustment screw -1- for side adjustment and screw -2- for height adjustment until proper adjustment is made.

Notes:

- ◆ *Also check whether both headlights work properly when the dynamic headlight adjustment is activated.*
- ◆ *The adjustment of the fog lights is automatically done with the adjustment of the headlights.*

Auxiliary driving lights:

Service-installed driving lights must be adjusted according to the applicable regulations.

**Note:**

VOL is correct beam pattern for both right and left headlights.

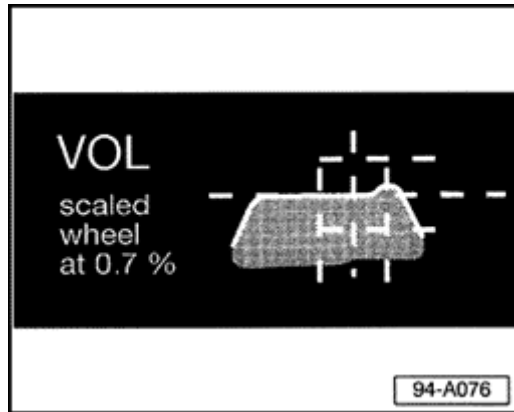

A

- Adjust lateral (horizontal) alignment of driver's side headlight (if possible) so that peak (highest point) of headlight beam pattern aligns with right edge of target box of grid on pattern screen (it should match VOL pattern shown on Beamsetter box).

Note:

If height alignment changed, readjust.



Headlights, adjusting (Vehicles from production date 10.00)

Note:

When adjusting the low beams, the high beams are automatically adjusted.

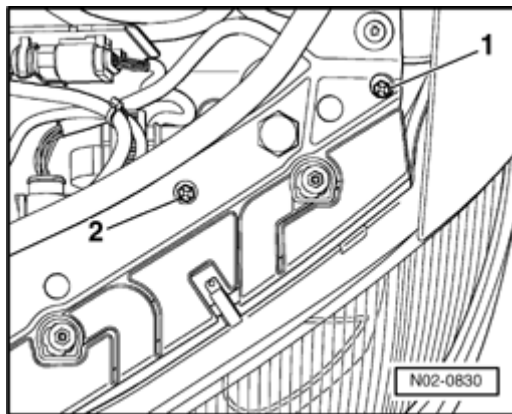

A Headlight, left:

1 - Side adjustment

2 - Height adjustment

The adjustment screws for the right headlight are positioned in mirror image.

- Guide Phillips screwdriver or socket with extension through hole in lock carrier.
- Turn adjustment screw for side adjustment -1- and height adjustment -2- until adjustment is attained.

Note:

VOL is correct beam pattern for both right and left headlights.



A

- Adjust lateral (horizontal) alignment of driver's side headlight (if possible) so that peak (highest point) of headlight beam pattern aligns with right edge of target box of grid on pattern screen (it should match VOL pattern shown on Beamsetter box).

Note:

If height alignment changed, readjust.



Fog light (right):

A

- To adjust fog lights, unclip cover -arrow- in lower part of bumper.

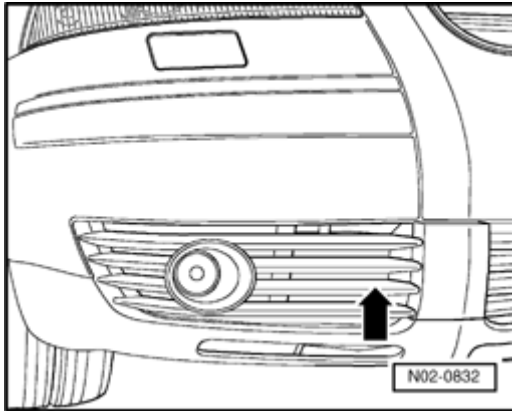
**A**

- To reduce the beam distance, turn adjustment screw -arrow- clockwise. There is no provision for side adjustment.

The adjustment of the left fog light is the reverse of the right.

Auxiliary driving lights:

Service-installed driving lights must be adjusted according to the applicable local regulations.

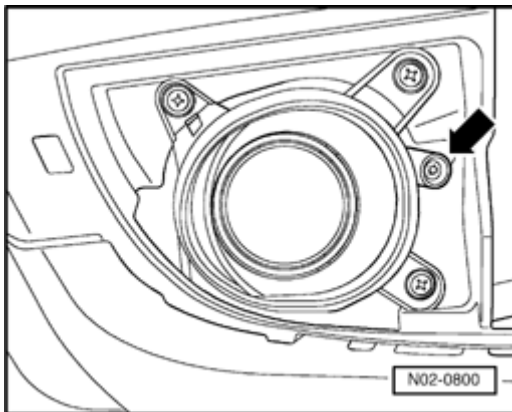



Driver's side headlight high beam alignment, checking

- Switch headlights ON in high beam position.
- Realign Beamsetter box with high beam headlight if necessary.
- Set Beamsetter "Scaled wheel" to 0%.
- Cover low beam lamp (use hand or small piece of cardboard) and check high beam pattern "hot spot" is centered on square target box of pattern screen.

Notes:

- ◆ *High beam pattern is built into reflector design and cannot be adjusted separately.*
- ◆ *If high beam pattern is way out of adjustment:*
 - Inspect for reflector damage.
 - Replace reflector if needed.

Note:

Always align headlight in low beam position.

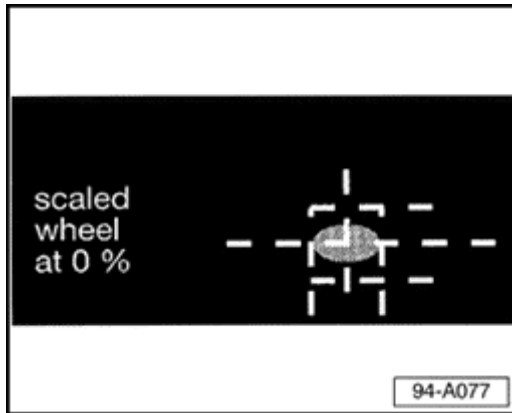



Fog lamp, alignment

- Switch fog lamps ON.

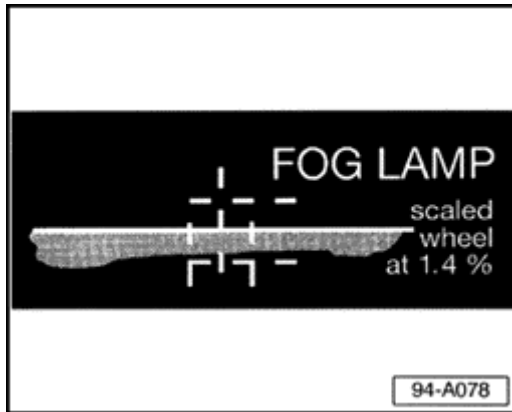

A

- Align Beamsetter box with fog lamp (make sure it is between 30 and 70 cm (12 to 28 in.) from fog lamp lens).
- Set Beamsetter scaled wheel to 1.4%.
- Adjust fog lamp so top of beam pattern aligns with center line of target grid on beam pattern screen.

Passenger's side headlight, alignment

- Move Beamsetter to passenger side of vehicle and follow same procedures to align Beamsetter box to head lamp.
- Align headlight low beam, check high beam and align fog lamp.

Note:

Make sure to reset Beamsetter "Scaled wheel" to proper setting each time you change from low beam to high beam or to fog lamp.

- Ensure headlights and vehicle body are clean and free of fingerprints.

Road test

The following checks depend on the vehicle equipment level and the available testing possibilities (city or urban streets).

During the road test, check the following:

- Engine: Performance, stalling, idle, acceleration

- Clutch: Driving off, pedal force, smell

- Gearshift: Easy movement, gearshift lever position

- Automatic transmission: Selector lever position, shiftlock / ignition key interlock, shift behavior, display in instrument cluster



- Foot and parking brake: Function, free-play and action, one-sided pull, chatter, squealing.
- ABS-Function: When braking with activated ABS, the brake pedal must pulse noticeably.
- Steering: Function, steering free-play, steering wheel center position when driving straight ahead.
- Power roof: Function
- Radio / radio navigation system: Function, reception, GALA, objectionable noise
- Multi-function display (MFA): Functions
- Air conditioning: Function
- Vehicle: Pulling to one side while driving straight ahead (level road)
- Imbalance: Wheels, axle joints

- Wheel bearings: Noise
- Engine: Hot-start function

RAPGARD® , inspection, removal and disposal

From my 2002

Service

Within 48 Hours after arrival at Dealer:

Inspection

- Inspect RAPGARD® for damage or peeling.

If RAPGARD® is disturbed (dented, scratched, etc.):

- You must note the damage on the Carrier Delivery Receipt, including damage type, extent and location. Failure to note damage on the Carrier Delivery Receipt will result in non-payment of the repair.

Within 72 Hours prior to delivery to the Customer:

- Remove RAPGARD® from vehicle.

- Wash vehicle exterior.
- Inspect paint surfaces, moldings and glass.
- Protect the paint surface of all new vehicles by applying 3M Perfect-It™ Paste Wax (3M Part No. 39526) or equivalent.

Removal

- ◆ Vehicle must be at room temperature.
- ◆ The ideal body surface temperature for RAPGARD[®] removal is 60 ° F (15.5 ° C) to 80 ° F (26.6 ° C).

If body surface temperatures are below 60 ° F (15.5 ° C) or above 80 ° F (26.6 ° C) then:

- Removal procedure should be performed indoors after surface temperatures have been allowed to stabilize within the given range.
- Rinse vehicle thoroughly with water to remove surface dirt or dust and to help stabilize body surface temperatures.
- Starting at the corners of each panel, carefully remove RAPGARD[®] from vehicle.

RAPGARD[®], paint inspection after removal

- Inspect painted surfaces under one of the

following lighting conditions:

- ◆ Indoors under fluorescent lighting.
- ◆ Outdoors under bright sunlight.

Important!:

If any defects on the exterior have been identified (scratches, dings, dents and other types of body damage):

- Contact your Service Manager and arrange to repair defects immediately.

Note:

After removal of RAPGARD[®], some vehicles may exhibit temporary paint discoloration or paint swelling (caused by trapped moisture under the RAPGARD[®]).

- ◆ *This temporary swelling is caused by the paint finish absorbing moisture trapped under the RAPGARD[®] film.*
- ◆ *This swelling will disappear with exposure to the sun or heat lamps within 2 - 3 hours. Severe Paint swelling may require 2 - 3 days to recover.*

DO NOT buff or refinish paint for this condition!

Adhesive residue removal

CAUTION!

***Always read and follow manufacturer
Cautions and Warnings regarding use of
product.***



If RAPGARD[®] adhesive residue remains on paint finish, remove with a non-abrasive polishing product such as, (3M Part No. 5995) light colors or (3M Part No. 5996) dark colors.

Thick lines of adhesive residue can be removed with general purpose adhesive cleaner (3M Part No. 08987-aerosol, or Part No, 08984-qt. can) or equivalent.

Note:

Paint discoloration (looks like shaded or dark magic marker lines) can be removed with a heat gun using the following procedure:

- Hold heat gun approximately 3 in. away from affected paint surfaces and apply heat using slow oscillating motions until discoloration is gone.
- If discoloration remains, wipe the heated area with Isopropyl alcohol and repeat procedure to increase surface drying.

Important!

After inspecting and removing RAPGARD[®], washing vehicle, inspecting and repairing any

defects in paint surfaces, moldings and glass:

- Protect the vehicle paint surface by applying 3M Perfect-It™ Paste Wax (3M Part No. 39526) or equivalent.

RAPGARD® Disposal

RAPGARD® can be disposed as normal paper waste. If unsure about proper disposal procedures in your area, check local regulations.

Transportation wiper blades, removing at vehicle delivery

Service

For all Models arriving at your dealership with transportation wiper blades:

Transportation wiper blades are shorter than original equipment wiper blades and colored blue or yellow.

Original equipment blades are temporarily installed during the Pre-Delivery Inspection to check wiper blade park position.

To ensure customer satisfaction, leave transportation wiper blades on vehicle until time of retail vehicle delivery.

Transportation wiper blades, removing

Transportation blades can easily be removed as follows:



A

- Grasp blade as shown and rotate in direction of arrow (toward windshield).

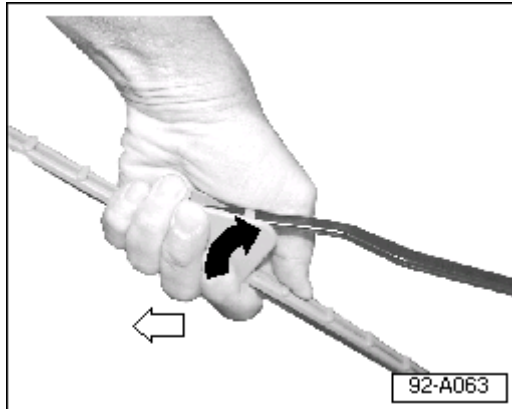

- A**
- Rotate blade in opposite direction (black arrow) then, carefully slide blade off wiper arm.

Note:

Wiper arm/blade alignment has been preset at the factory, then checked and adjusted (if necessary) during the PDI.

DO NOT twist or bend the wiper arm. If wiper arm/blade alignment is incorrect, chattering and/or streaking will occur.

If arm has been bent:

⇒ [Repair Manual, Electrical Equipment, Repair Group 92](#)

- Install original equipment wiper blades (located in trunk) at the time of retail vehicle delivery.

Note:

- A**
- ◆ *Wiper blade with air deflector (arrow) must be installed on driver's side with deflector on bottom of wiper blade.*

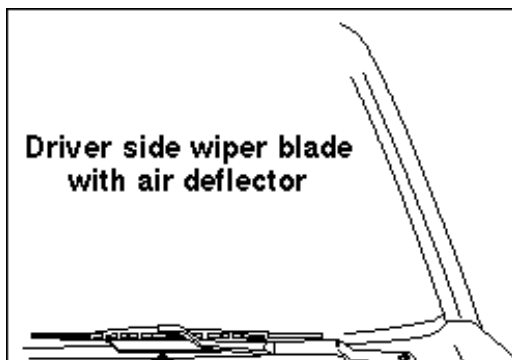

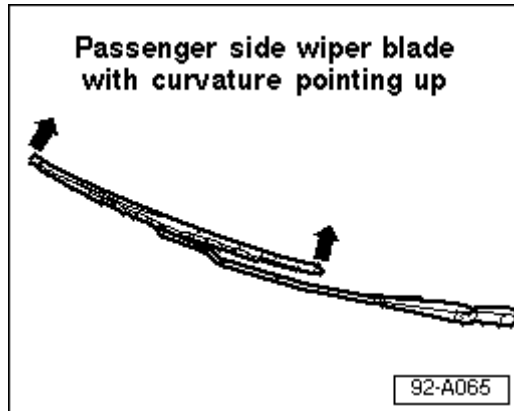

A

- ◆ *Passenger's side wiper blade may be curved, install with curved ends of blade pointing up.*